

The background of the entire page is a close-up, high-angle photograph of several carbon steel pipes. The pipes are arranged in a grid-like pattern, with some in the foreground and others receding into the background. The lighting is dramatic, highlighting the metallic texture and the circular openings of the pipes. The overall color palette is monochromatic, consisting of various shades of grey, blue, and black.

ASD

CARBON STEEL BUYERS GUIDE

eProcurement Solutions



Online Shop



Punchout



EDI

ASD delivers innovative eProcurement solutions by investing in people, processes and technology, always adding value for our customers.

All our eProcurement solutions have been created to ease your daily business and eliminate unnecessary manual efforts. Whether you decide to implement the Online Shop, Punchout or EDI as your preferred purchasing solution, our experts will be there to assist you every step of the way.

Get in touch today with your ASD representative to find out more.

Introduction

ASD is the largest mill independent multi-metal stockholder & distributor in the UK. We offer a diverse range of ferrous and non-ferrous products sourced from reputable and accredited mill sources across Western Europe.

We operate in all major market sectors across the UK and are renowned for our unrivaled ability to meet clients requirements by developing innovative value added services and introducing digital solutions.

Quality

We take Quality and Health & Safety seriously and you can be assured that excellence is at the heart of our mission statement. The team at ASD are aware of the importance of maintaining company certifications and are committed to ensuring our management systems and processes are up to the highest standards with regards to Quality, Health & Safety and Environment.

Our key Quality, Health & Safety and Environment certifications include:

ISO 9001:2015

ISO 45001:2018

ISO 14001:2015

BSI BES 6001

National Highway Sector Scheme 3B (NHSS3B)



Contents

Joists & Universal Beams	5-7
Universal Columns	8
Channels	9
Continental Sections	10-13
Angles & Flats	14-18
Trailer Flats	19
Rounds & Squares	19
Hollow Section Cold Formed	20-23
Hollow Section Hot Finished	24-27
Flat Products	28-29
Reversing Mill Plate	30-33
COR-TEN	34
ERW Tube	35-37
Tubes & Fittings	38-43
Handrails	44-47
Flooring & Mesh	48-63
Engineering Steel	64-69
Technical Information	70-76
Value Added Services	77

DISCLAIMER

The content of the pages of this buyers guide are for your general information and use only. ASD Limited does not warranty or guarantee as to the accuracy of the information which has been provided by a variety of third party sources.

Joists & Universal Beams

EN10025-2 S355JR / J0

Description	kg/m	Depth of section mm	Width of section mm	Thickness of web mm	Thickness of flange mm
Joists					
102 x 44 x 7	7.5	101.6	44.5	4.3	6.1
Universal Beams					
127 x 76 x 13	13.0	127.0	76.0	4.0	7.6
152 x 89 x 16	16.0	152.4	88.7	4.5	7.7
178 x 102 x 19	19.0	177.8	101.2	4.8	7.9
203 x 102 x 23	23.1	203.2	101.8	5.4	9.3
203 x 133 x 25	25.1	203.2	133.2	5.7	7.8
203 x 133 x 30	30.0	206.8	133.9	6.4	9.6
203 x 203 x 100	99.6	228.6	210.3	14.5	23.7
203 x 203 x 113	113.5	235.0	212.1	16.3	26.9
254 x 102 x 22	22.0	254.0	101.6	5.7	6.8
254 x 102 x 25	25.2	257.2	101.9	6.0	8.4
254 x 102 x 28	28.3	260.4	102.2	6.3	10.0
254 x 146 x 31	31.1	251.4	146.1	6.0	8.6
254 x 146 x 37	37.0	256.0	146.4	6.3	10.9
254 x 146 x 43	43.0	259.6	147.3	7.2	12.7
305 x 102 x 25	24.8	305.1	101.6	5.8	7.0
305 x 102 x 28	28.2	308.7	101.8	6.0	8.8
305 x 102 x 33	32.8	312.7	102.4	6.6	10.8
305 x 127 x 37	37.0	304.4	123.3	7.1	10.7
305 x 127 x 42	41.9	307.2	124.3	8.0	12.1
305 x 127 x 48	48.1	311.0	125.3	9.0	14.0
305 x 165 x 40	40.3	303.4	165.0	6.0	10.2
305 x 165 x 46	46.1	306.6	165.7	6.7	11.8
305 x 165 x 54	54.0	310.4	166.9	7.9	13.7
356 x 127 x 33	33.1	349.0	125.4	6.0	8.5
356 x 127 x 39	39.1	353.4	126.0	6.6	10.7
356 x 171 x 45	45.0	351.4	171.1	7.0	9.7
356 x 171 x 51	51.0	355.0	171.5	7.4	11.5
356 x 171 x 57	57.0	358.0	172.2	8.1	13.0
356 x 171 x 67	67.1	363.4	173.2	9.1	15.7

Universal Beams

EN10025-2 S355JR / JO

Description	kg/m	Depth of section mm	Width of section mm	Thickness of web mm	Thickness of flange mm
406 x 140 x 39	39.0	398.0	141.8	6.4	8.6
406 x 140 x 46	46.0	403.2	142.2	6.8	11.2
406 x 140 x 53	53.3	406.6	143.3	7.9	12.9
406 x 178 x 54	54.1	402.6	177.7	7.7	10.9
406 x 178 x 60	60.1	406.4	177.9	7.9	12.8
406 x 178 x 85	85.3	417.2	181.9	10.9	18.2
406 x 178 x 67	67.1	409.4	178.8	8.8	14.3
406 x 178 x 74	74.2	412.8	179.5	9.5	16.0
457 x 152 x 52	52.3	449.8	152.4	7.6	10.9
457 x 152 x 60	59.8	454.6	152.9	8.1	13.3
457 x 152 x 67	67.2	458.0	153.8	9.0	15.0
457 x 152 x 74	74.2	462.0	154.4	9.6	17.0
457 x 152 x 82	82.1	465.8	155.3	10.5	18.9
457 x 191 x 67	67.1	453.4	189.9	8.5	12.7
457 x 191 x 74	74.3	457.0	190.4	9.0	14.5
457 x 191 x 82	82.0	460.0	191.3	9.9	16.0
457 x 191 x 89	89.3	463.4	191.9	10.5	17.7
457 x 191 x 98	98.3	467.2	192.8	11.4	19.6
457 x 191 x 106	105.8	469.2	194.0	12.6	20.6
457 x 191 x 133	133.3	480.6	196.7	15.3	26.3
457 x 191 x 161	161.4	492.0	199.4	18.0	32.0
553 x 165 x 66	65.7	524.7	165.1	8.9	11.4
553 x 165 x 74	74.7	529.1	165.9	9.7	13.6
553 x 165 x 85	84.8	534.9	166.5	10.3	16.5
533 x 210 x 82	82.2	528.3	208.8	9.6	13.2
533 x 210 x 92	92.1	533.1	209.3	10.1	15.6
533 x 210 x 101	101.0	536.7	210.0	10.8	17.4
533 x 210 x 109	109.0	539.5	210.8	11.6	18.8
533 x 210 x 122	122.0	544.5	211.9	12.7	21.3
533 x 210 x 138	138.3	549.1	213.9	14.7	23.6
553 x 312 x 150	150.6	542.5	312.0	12.7	20.3
553 x 312 x 182	181.5	550.7	314.5	15.2	24.4
553 x 312 x 219	218.8	560.3	317.4	18.3	29.2
553 x 312 x 272	273.3	577.1	320.2	21.1	37.6
610 x 229 x 101	101.2	602.6	227.6	10.5	14.8
610 x 229 x 113	113.0	607.6	228.2	11.1	17.3
610 x 229 x 125	125.1	612.2	229.0	11.9	19.6
610 x 229 x 140	139.9	617.2	230.2	13.1	22.1
610 x 305 x 149	149.1	612.4	304.8	11.8	19.7
610 x 305 x 179	179.0	620.2	307.1	14.1	23.6
610 x 305 x 238	238.1	635.8	311.4	18.4	31.4
686 x 254 x 125	125.2	677.9	253.0	11.7	16.2
686 x 254 x 140	140.1	683.5	253.7	12.4	19.0
686 x 254 x 152	152.4	687.5	254.5	13.2	21.0
686 x 254 x 170	170.2	692.9	255.8	14.5	23.7

● **Please note:** These items are offered as mill rolling only

Universal Beams

EN10025-2 S355JR / J0

Description	kg/m	Depth of section mm	Width of section mm	Thickness of web mm	Thickness of flange mm
● 610 x 178 x 82	81.8	598.6	177.9	10.0	12.8
● 610 x 178 x 92	92.2	603.0	178.8	10.9	15.0
● 610 x 178 x 100	100.3	607.4	179.2	11.3	17.2
762 x 267 x 134	133.9	750.0	264.4	12.0	15.5
762 x 267 x 147	146.9	754.0	265.2	12.8	17.5
762 x 267 x 173	173.0	762.2	266.7	14.3	21.6
762 x 267 x 197	196.8	769.8	268.0	15.6	25.4
838 x 292 x 176	175.9	834.9	291.7	14.0	18.8
838 x 292 x 194	193.8	840.7	292.4	14.7	21.7
838 x 292 x 226	226.5	850.9	293.8	16.1	26.8
914 x 305 x 201	200.9	903.0	303.3	15.1	20.2
914 x 305 x 224	224.2	910.4	304.1	15.9	23.9
914 x 305 x 253	253.4	918.4	305.5	17.3	27.9
914 x 305 x 289	289.1	926.6	307.7	19.5	32.0
914 x 419 x 343	343.3	911.8	418.5	19.4	32.0
914 x 419 x 388	388.0	921.0	420.5	21.4	36.6
● 1016 x 305 x 222	222.0	970.3	300.0	16.0	21.1
● 1016 x 305 x 249	248.7	980.1	300.0	16.5	26.0
● 1016 x 305 x 272	272.3	990.1	300.0	16.5	31.0
● 1016 x 305 x 314	314.3	999.9	300.0	19.1	35.9
● 1016 x 305 x 349	349.4	1008.1	302.0	21.1	40.0
● 1016 x 305 x 393	392.7	1015.9	303.0	24.4	43.9
● 1016 x 305 x 437	437.0	1026.1	305.4	26.9	49.0
● 1016 x 305 x 487	486.7	1036.3	308.5	30.0	54.1

- **Please note:** These items are offered as mill rolling only

Universal Columns

EN10025-2 S355JR / J0

Description	kg/m	Depth of section mm	Width of section mm	Thickness of web mm	Thickness of flange mm
152 x 152 x 23	23.0	152.4	152.2	5.8	6.8
152 x 152 x 30	30.0	157.6	152.2	6.5	9.4
152 x 152 x 37	37.0	161.8	154.4	8.0	11.5
152 x 152 x 44	44.0	166.0	155.9	9.5	13.6
152 x 152 x 51	44.0	166.0	155.9	9.5	13.6
203 x 203 x 46	46.1	203.2	203.6	7.2	11.0
203 x 203 x 52	52.0	206.2	204.3	7.9	12.5
203 x 203 x 60	60.0	209.6	205.8	9.4	14.2
203 x 203 x 71	71.0	215.8	206.4	10.0	17.3
203 x 203 x 86	86.1	222.2	209.1	12.7	20.5
203 x 203 x 100	99.6	228.6	210.3	14.5	23.7
203 x 203 x 113	113.5	235.0	212.1	16.3	26.9
203 x 203 x 127	127.5	241.4	213.9	18.1	30.1
254 x 254 x 73	73.1	254.1	254.6	8.6	14.2
254 x 254 x 89	88.9	260.3	256.3	10.3	17.3
254 x 254 x 107	107.1	266.7	258.3	12.8	20.5
254 x 254 x 132	132.0	276.3	261.3	15.3	25.3
254 x 254 x 167	167.1	289.1	265.2	19.2	31.7
305 x 305 x 97	96.9	307.9	305.3	9.9	15.4
305 x 305 x 118	117.9	314.5	307.4	12.0	18.7
305 x 305 x 137	136.9	320.5	309.2	13.8	21.7
305 x 305 x 158	158.1	327.1	311.2	15.8	25.0
305 x 305 x 198	198.1	339.9	314.5	19.1	31.4
305 x 305 x 240	240.0	352.5	318.4	23.0	37.7
305 x 305 x 283	282.9	365.3	322.2	26.8	44.1
356 x 368 x 129	129.0	355.6	368.6	10.4	17.5
356 x 368 x 153	152.9	362.0	370.5	12.3	20.7
356 x 368 x 177	177.0	368.2	372.6	14.4	23.8
356 x 368 x 202	201.9	374.6	374.7	16.5	27.0
356 x 406 x 235	235.1	381.0	394.8	18.4	30.2
356 x 406 x 287	287.1	393.6	399.0	22.6	36.5
356 x 406 x 340	339.9	406.4	403.0	26.6	42.9
356 x 406 x 393	393.0	419.0	407.0	30.6	49.2
356 x 406 x 467	467.0	436.6	412.2	35.8	58.0
356 x 406 x 551	551.0	455.6	418.5	42.1	67.5
356 x 406 x 634	633.9	474.6	424.0	47.6	77.0

● **Please note:** These items are offered as mill rolling only

Channels

EN10025-2 S275JR / S355JR

Description	kg/m	Depth of section mm	Width of section mm	Thickness of web mm	Thickness of flange mm
40 x 20 x 5	2.69	40	20	5.5	5.5
50 x 25 x 5	3.98	50	25	6.0	6.0
50 x 38 x 5	5.15	50	38	7.0	7.0
76 x 38 x 6.7	6.90	76	38	5.1	6.8
80 x 45 x 8.64	8.90	80	45	6.0	8.0
100 x 50 x 10	10.20	100	50	5.0	8.5
125 x 65 x 15	14.80	125	65	5.5	9.5
150 x 75 x 18	17.90	150	75	5.5	10.0
150 x 90 x 24	23.90	150	90	6.5	12.0
180 x 75 x 20	20.30	180	75	6.0	10.5
180 x 90 x 26	26.10	180	90	6.5	12.5
200 x 75 x 23	23.40	200	75	6.0	12.5
200 x 90 x 30	29.70	200	90	7.0	14.0
230 x 75 x 26	25.70	230	75	6.5	12.5
230 x 90 x 32	32.20	230	90	7.5	14.0
260 x 75 x 28	27.60	260	75	7.0	12.0
260 x 90 x 35	34.80	260	90	8.0	14.0
300 x 90 x 41	41.40	300	90	9.0	15.5
300 x 100 x 46	45.50	300	100	9.0	16.5
380 x 100 x 54	54.00	380	100	9.5	17.5
430 x 100 x 64	64.40	430	100	11.0	19.0

Continental IPN Section

Description	Dimensions				kg/m
	h mm	b mm	a mm	e mm	
80	80	42	3.9	5.9	5.95
100	100	50	4.5	6.8	8.32
120	120	58	4.1	7.7	11.2
140	140	66	5.7	8.6	14.4
160	160	74	6.3	9.5	17.9
180	180	82	6.9	10.4	21.9
200	200	90	7.5	11.3	26.3
220	220	98	8.1	12.2	31.1
240	240	106	8.7	13.1	36.2
260	260	113	9.4	14.1	41.9
280	280	119	10.1	15.2	48.0
300	300	125	10.8	16.2	54.2
320	320	131	11.5	17.3	61.1
340	340	137	12.2	18.3	68.1
360	360	143	13.0	19.5	76.2
380	380	149	13.7	20.5	84.0
400	400	155	14.4	21.6	92.6
450	450	170	16.2	24.3	115.0
500	500	185	18.0	27.0	141.0

Continental HEA Section

Description	Dimensions				kg/m
	h mm	b mm	a mm	e mm	
100	96	100	5.0	8.0	16.7
120	114	120	5.0	8.0	19.9
140	133	140	5.5	8.5	24.7
160	152	160	6.0	9.0	30.4
180	171	180	6.0	9.5	35.5
200	190	200	6.5	10.0	42.3
220	210	220	7.0	11.0	50.5
240	230	240	7.5	12.0	60.3
260	250	260	7.5	12.5	68.2
280	270	280	8.0	13.0	76.4
300	290	300	8.5	14.0	88.3
320	310	300	9.0	15.5	97.6
340	330	300	9.5	16.5	105.0
360	350	300	10.0	17.5	112.0
400	390	300	11.0	19.0	125.0
450	440	300	11.5	21.0	140.0
500	490	300	12.0	23.0	155.0

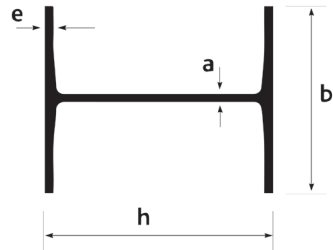
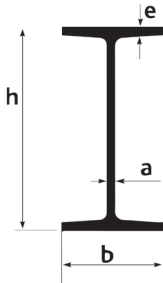

Continental HEB Section

Description	Dimensions				kg/m
	h mm	b mm	a mm	e mm	
100	100	100	6.0	10.0	20.4
120	120	120	6.5	11.0	26.7
140	140	140	7.0	12.0	33.7
160	160	160	8.0	13.0	42.6
180	180	180	8.5	14.0	51.2
200	200	200	9.0	15.0	61.3
220	220	220	9.5	16.0	71.5
240	240	240	10.0	17.0	83.2
260	260	260	10.0	17.5	93
280	280	280	10.5	18.0	103
300	300	300	11.0	19.0	117
320	320	300	11.5	20.5	127
340	340	300	12.0	21.5	134
360	360	300	12.5	22.5	142
400	400	300	13.5	24.0	155
450	450	300	14.0	26.0	171
500	500	300	14.5	28.0	187

Continental HEM Section

Description	Dimensions				kg/m
	h mm	b mm	a mm	e mm	
100	120	106	12.0	20.0	41.8
120	140	126	12.5	21.0	52.1
140	160	146	13.0	22.0	63.2
160	180	166	14.0	23.0	76.2
180	200	186	14.5	24.0	88.9
200	220	206	15.0	25.0	103
220	240	226	15.5	26.0	117
240	270	248	18.0	32.0	157
260	290	268	18.0	32.5	172
280	310	288	18.5	33.0	189
300	340	310	21.0	39.0	238
320	359	309	21.0	40.0	245
340	377	309	21.0	40.0	245
360	395	308	21.0	40.0	250
400	432	307	21.0	40.0	256
450	478	307	21.0	40.0	263
500	524	306	21.0	40.0	270

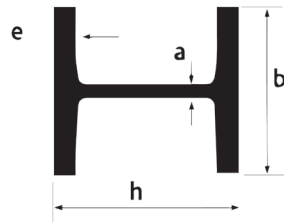
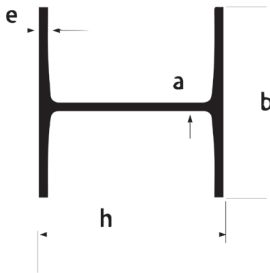

Continental UPN Section

Description	Dimensions				kg/m
	h mm	b mm	a mm	e mm	
80	80	45	6.0	8.0	8.64
100	100	50	6.0	8.5	10.6
120	120	55	7.0	9.0	13.4
140	140	60	7.0	10.0	16.0
160	160	65	7.5	10.5	18.8
180	180	70	8.0	11.0	22.0
200	200	75	8.5	11.5	25.3
220	220	80	9.0	12.5	29.4
240	240	85	9.5	13.0	33.2
260	260	90	10.0	14.0	37.9
280	280	95	10.0	15.5	41.8
300	300	100	10.0	16.0	46.2
320	320	100	14.0	17.5	59.5
350	350	100	14.0	16.0	60.6
380	380	102	13.5	16.0	62.6
400	400	110	14.0	18.0	71.8

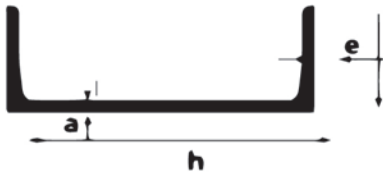

Continental IPE Section

Description	Dimensions				kg/m
	h mm	b mm	a mm	e mm	
80	80	46	3.8	5.2	6.0
100	100	55	4.1	5.7	8.1
120	120	64	4.4	6.3	10.4
140	140	73	4.7	6.9	12.9
160	160	82	5.0	7.4	15.8
180	180	91	5.3	8.0	18.8
200	200	100	5.6	8.5	22.4
220	220	110	5.9	9.2	26.2
240	240	120	6.2	9.8	30.7
270	270	135	6.6	10.2	36.1
300	300	150	7.1	10.7	42.2
330	330	160	7.5	11.5	49.1
360	360	170	8.0	12.7	57.1
400	400	180	8.6	13.5	66.3
450	450	190	9.4	14.6	77.6
500	500	200	10.2	16.0	90.7

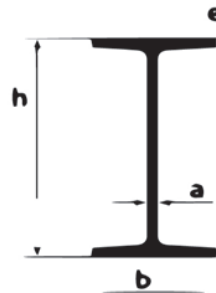

Continental IPA/IPEA Section

Description	Dimensions				kg/m
	h mm	b mm	a mm	e mm	
80	78	46	3.3	4.2	5.0
100	98	55	3.6	4.7	6.9
120	117.6	64	3.8	5.1	8.6
140	137.4	73	3.8	5.6	10.5
160	157	82	4.0	5.9	12.7
180	177	91	4.3	6.5	15.4
200	197	100	4.5	7.0	18.4
220	217	110	5.0	7.7	22.2
240	237	120	5.2	8.3	26.2
270	267	135	5.5	8.7	30.7
300	297	150	6.1	9.2	36.5
330	327	160	6.5	10.0	43.0
360	357.6	170	6.6	11.5	50.2
400	397	180	7.0	12.0	57.4
450	447	190	7.6	13.1	67.2
500	497	200	8.4	14.5	79.4

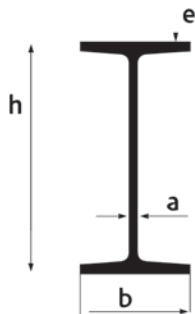

Unequal Angles

EN10025-2 S275JR / S355JR

Size mm	kg/m	Size mm	kg/m	Size mm	kg/m
30 x 20 x 4	1.46	80 x 40 x 6	5.41	150 x 75 x 12	20.20
30 x 20 x 5	1.78	80 x 40 x 8	7.07	150 x 75 x 15	24.80
40 x 20 x 5	2.17	80 x 60 x 6	6.37	150 x 90 x 10	18.20
40 x 25 x 4	1.93	80 x 60 x 8	8.34	150 x 90 x 12	21.60
40 x 25 x 5	2.37	80 x 65 x 6	6.83	150 x 90 x 15	26.60
50 x 30 x 5	2.96	80 x 65 x 8	9.11	200 x 100 x 10	23.00
50 x 40 x 5	3.37	80 x 65 x 10	11.38	200 x 100 x 12	27.30
50 x 40 x 6	3.99	90 x 65 x 6	7.31	200 x 100 x 18	47.10
60 x 30 x 5	3.37	90 x 65 x 8	9.73	200 x 150 x 12	32.00
60 x 30 x 6	3.99	100 x 50 x 6	6.85	200 x 150 x 15	39.60
60 x 40 x 5	3.77	100 x 50 x 8	8.99	200 x 150 x 18	47.10
60 x 40 x 6	4.46	100 x 50 x 10	11.11		
65 x 50 x 5	4.35	100 x 65 x 7	8.77		
65 x 50 x 6	5.16	100 x 65 x 8	9.94		
65 x 50 x 8	6.75	100 x 65 x 10	12.30		
70 x 50 x 8	5.42	100 x 75 x 8	10.60		
75 x 50 x 5	4.59	100 x 75 x 10	13.00		
75 x 50 x 6	5.65	100 x 75 x 12	15.40		
75 x 50 x 7	6.53	125 x 75 x 8	12.20		
75 x 50 x 8	7.39	125 x 75 x 10	15.00		
75 x 50 x 10	9.12	125 x 75 x 12	17.80		
		150 x 75 x 10	17.00		

Equal Angles

EN10025-2 S275JR / S355JR

Size mm	kg/m
13 x 13 x 3	0.55
16 x 16 x 3	0.71
20 x 20 x 3	0.88
25 x 25 x 3	1.12
25 x 25 x 5	1.78
25 x 25 x 6	2.22
30 x 30 x 3	1.36
30 x 30 x 5	2.18
30 x 30 x 6	2.57
35 x 35 x 5	2.59
35 x 35 x 6	3.05
40 x 40 x 3	1.84
40 x 40 x 4	2.42
40 x 40 x 5	2.97
40 x 40 x 6	3.52
45 x 45 x 3	2.11
45 x 45 x 5	3.38
45 x 45 x 6	4.01
50 x 50 x 3	2.33
50 x 50 x 4	3.08
50 x 50 x 5	3.77
50 x 50 x 6	4.47
50 x 50 x 8	5.82
60 x 60 x 5	4.57
60 x 60 x 6	5.42
60 x 60 x 7	6.25
60 x 60 x 8	7.09
60 x 60 x 10	8.69

Tee Sections

EN10025-2 S275JR

Size mm	kg/m	Size mm	kg/m	Size mm	kg/m
65 x 65 x 6	6.15	25 x 25 x 3	1.19		
65 x 65 x 8	8.16	30 x 30 x 5	2.16		
70 x 70 x 5	5.15	40 x 40 x 5	2.96		
70 x 70 x 6	6.38	40 x 40 x 6	3.49		
70 x 70 x 8	8.36	50 x 50 x 6	4.76		
70 x 70 x 9	9.89	70 x 70 x 8	8.35		
70 x 70 x 10	10.31				
75 x 75 x 6	6.87				
75 x 75 x 8	9.01				
75 x 75 x 10	11.11				
75 x 75 x 12	13.07				
80 x 80 x 6	7.34				
80 x 80 x 8	9.63				
80 x 80 x 10	11.90				
80 x 80 x 12	14.20				
90 x 90 x 6	8.30				
90 x 90 x 8	10.90				
90 x 90 x 9	12.72				
90 x 90 x 10	13.40				
90 x 90 x 12	15.90				
100 x 100 x 8	12.20				
100 x 100 x 10	15.00				
100 x 100 x 12	17.80				
100 x 100 x 15	21.90				
120 x 120 x 8	14.70				
120 x 120 x 10	18.20				
120 x 120 x 12	21.60				
120 x 120 x 15	26.60				
150 x 150 x 10	23.00				
150 x 150 x 12	27.30				
150 x 150 x 15	33.80				
150 x 150 x 18	40.10				
200 x 200 x 12	36.74				
200 x 200 x 16	48.50				
200 x 200 x 18	54.20				
200 x 200 x 20	59.90				
200 x 200 x 24	71.10				

Black Flats

EN10025-2 S275JR / S355JR

Size mm	kg/m	Size mm	kg/m	Size mm	kg/m
10 x 3	0.26	40 x 3	0.95	65 x 3	1.53
13 x 3	0.33	40 x 5	1.57	65 x 5	2.55
13 x 5	0.51	40 x 6	1.88	65 x 6	3.06
13 x 6	0.61	40 x 8	2.51	65 x 8	4.08
15 x 3	0.36	40 x 10	3.14	65 x 10	5.11
15 x 5	0.59	40 x 12	3.77	65 x 12	6.12
16 x 3	0.39	40 x 15	4.71	65 x 15	7.65
16 x 5	0.63	40 x 20	6.28	65 x 20	10.21
16 x 6	0.75	40 x 25	7.85	65 x 25	12.76
16 x 8	0.99	40 x 30	9.42	65 x 30	15.31
16 x 10	1.26	45 x 3	1.06	65 x 35	17.85
20 x 3	0.49	45 x 5	1.77	65 x 40	20.41
20 x 5	0.79	45 x 6	2.12	65 x 45	22.96
20 x 6	0.94	45 x 8	2.83	65 x 50	25.52
20 x 8	1.26	45 x 10	3.53	70 x 3	1.65
20 x 10	1.57	45 x 12	4.24	70 x 5	2.76
20 x 12	1.88	45 x 15	5.31	70 x 6	3.31
25 x 3	0.63	45 x 20	7.07	70 x 8	4.39
25 x 5	0.98	45 x 25	8.73	70 x 10	5.49
25 x 6	1.18	45 x 30	10.65	70 x 12	6.59
25 x 8	1.57	50 x 3	1.25	70 x 15	8.24
25 x 10	1.96	50 x 5	1.96	70 x 20	10.99
25 x 12	2.36	50 x 6	2.36	70 x 25	13.74
25 x 15	2.94	50 x 8	3.14	70 x 30	16.49
25 x 20	3.92	50 x 10	3.93	70 x 40	21.96
30 x 3	0.75	50 x 12	4.72	70 x 50	27.48
30 x 5	1.18	50 x 15	5.89	75 x 3	1.77
30 x 6	1.41	50 x 20	7.85	75 x 5	2.97
30 x 8	1.88	50 x 25	9.81	75 x 6	3.55
30 x 10	2.36	50 x 30	11.78	75 x 8	4.71
30 x 12	2.83	50 x 40	15.71	75 x 10	5.89
30 x 15	3.53	60 x 3	1.44	75 x 12	7.05
30 x 20	4.71	60 x 5	2.36	75 x 20	11.81
30 x 25	5.89	60 x 6	2.83	75 x 25	14.71
35 x 3	0.85	60 x 8	3.77	75 x 30	17.71
35 x 5	1.37	60 x 10	4.71		
35 x 10	2.75	60 x 12	5.65		
35 x 12	3.37	60 x 15	7.07		
35 x 15	4.21	60 x 20	9.42		
		60 x 25	11.78		
		60 x 30	14.13		
		60 x 35	16.49		
		60 x 40	18.84		

Black Flats

EN10025-2 S275JR / S355JR

Size mm	kg/m	Size mm	kg/m	Size mm	kg/m
75 x 40	23.61	100 x 65	76.65	140 x 30	32.99
75 x 50	29.45	100 x 75	58.95	150 x 3	3.54
75 x 60	35.45			150 x 5	5.89
75 x 65	38.32	110 x 3	2.59	150 x 6	7.09
80 x 3	1.89	110 x 5	4.32	150 x 8	9.42
80 x 5	3.14	110 x 6	5.18	150 x 10	11.78
80 x 6	3.77	110 x 8	6.91	150 x 12	14.13
80 x 8	5.02	110 x 10	8.64	150 x 15	17.66
80 x 10	6.28	110 x 12	10.41	150 x 20	23.55
80 x 12	7.54	110 x 15	12.95	150 x 25	29.44
80 x 15	9.42	110 x 20	17.27	150 x 30	35.33
80 x 20	12.56	110 x 25	21.59	150 x 40	47.11
80 x 25	15.71	110 x 30	25.89	150 x 45	52.99
80 x 30	18.84	110 x 40	34.54	150 x 50	58.88
80 x 35	22.02	110 x 45	38.36	150 x 60	70.65
80 x 40	25.12	110 x 50	43.18	150 x 75	88.32
80 x 45	28.26				
80 x 50	31.41	120 x 5	4.71	160 x 6	7.54
80 x 60	37.68	120 x 6	5.66	160 x 10	12.56
80 x 65	40.82	120 x 8	7.54	160 x 12	15.07
		120 x 10	9.42	160 x 15	18.81
90 x 3	2.12	120 x 12	11.31	160 x 20	25.12
90 x 5	3.53	120 x 15	14.09	160 x 25	31.40
90 x 6	4.24	120 x 20	18.84		
90 x 8	5.65	120 x 25	23.55	180 x 6	8.48
90 x 10	7.07	120 x 30	28.35	180 x 8	11.31
90 x 12	8.48			180 x 10	14.13
90 x 15	10.61	130 x 3	3.06	180 x 12	16.96
90 x 20	14.13	130 x 5	5.11	180 x 15	21.22
90 x 25	17.68	130 x 6	6.12	180 x 20	28.26
90 x 30	21.22	130 x 8	8.16	180 x 25	35.33
90 x 35	24.73	130 x 8	8.16	180 x 30	42.39
90 x 40	28.26	130 x 10	10.21	180 x 40	56.52
90 x 45	31.79	130 x 12	12.25	180 x 50	70.65
90 x 50	35.33	130 x 15	15.31		
		130 x 20	20.41	200 x 6	9.42
100 x 3	2.36	130 x 25	25.51	200 x 8	12.59
100 x 5	3.93	130 x 30	30.62	200 x 10	15.69
100 x 6	4.71	130 x 40	40.81	200 x 12	18.84
100 x 8	6.28	130 x 45	45.92	200 x 15	23.55
100 x 10	7.85	130 x 50	51.03	200 x 20	31.41
100 x 12	9.42	130 x 60	61.23	200 x 25	39.25
100 x 15	11.78	130 x 75	76.51	200 x 30	47.11
100 x 20	15.72			200 x 40	62.81
100 x 25	19.63	140 x 6	6.59	200 x 45	70.65
100 x 30	23.55	140 x 8	8.79	200 x 50	78.51
100 x 35	27.48	140 x 10	10.99	200 x 75	117.75
100 x 40	31.41	140 x 12	13.25		
100 x 45	35.33	140 x 15	16.48	220 x 6	10.36
100 x 50	39.25	140 x 20	21.98	220 x 8	13.82
100 x 60	47.11	140 x 25	27.48	220 x 10	17.27

Black Flats

EN10025-2 S275JR / S355JR

Size mm	kg/m
220 x 12	20.72
220 x 15	25.91
220 x 20	34.54
220 x 25	43.18
220 x 30	51.81
220 x 40	69.08
220 x 50	86.35
250 x 6	11.78
250 x 8	15.69
250 x 10	19.59
250 x 12	23.55
250 x 15	29.44
250 x 20	39.25
250 x 25	49.06
250 x 30	58.88
250 x 40	78.51
250 x 45	88.31
250 x 50	98.13
275 x 10	21.59
275 x 12	25.90
275 x 15	32.38
275 x 20	43.18
300 x 6	14.13
300 x 8	18.84
300 x 10	23.55
300 x 12	28.26
300 x 15	35.33
300 x 20	47.15
300 x 25	58.88
300 x 30	70.65
300 x 40	94.22
300 x 45	105.98
300 x 50	117.75

Feathered Edge Convex

EN10025-2 S275JR

Size mm	kg/m
350 x 10	27.48
350 x 12	33.01
350 x 15	41.25
350 x 20	54.95
350 x 25	68.69
350 x 30	82.43
350 x 40	109.89
400 x 10	31.41
400 x 12	37.68
400 x 15	47.09
400 x 20	62.81
400 x 25	78.51
400 x 30	94.21
400 x 40	125.61
450 x 10	35.33
450 x 12	42.39
450 x 15	52.99
450 x 20	70.65
450 x 25	88.31
500 x 10	39.25
500 x 12	47.10
500 x 15	58.88
500 x 20	78.50
500 x 25	98.13

Size mm	kg/m
19 x 4.8	0.49
19 x 6.4	0.67
19 x 10.0	1.10
25 x 4.8	0.64
25 x 6.0	0.86
25 x 10.0	1.37
32 x 6.0	1.07
32 x 10.0	1.65
38 x 6.0	1.26
38 x 10.0	1.95
38 x 13.0	3.18
51 x 10.0	2.60
51 x 13.0	4.17

Square Edge Convex

EN10025-2 S275JR

Size mm	kg/m
38 x 13 x 6.4	3.18
51 x 13 x 6.4	4.17

Trailer Flats

EN10025-2 S355JR

Product
100 x 6
100 x 8
100 x 10
100 x 12
100 x 15
100 x 20
120 x 8
120 x 10
120 x 12
120 x 15
130 x 8
130 x 10
130 x 12
130 x 15
150 x 12
130 x 20
140 x 12
140 x 20
150 x 10
150 x 15
150 x 20

*All sizes are Cold
Side Straightened

Black Rounds

EN10025-2 S275JR / S355JR

Size mm	kg/m
6	0.22
8	0.39
10	0.62
12	0.89
12.5	0.96
16	1.58
20	2.47
22	2.98
25	3.85
30	5.55
32	6.31
35	7.55
38	8.91
40	9.86
45	12.51
50	15.41
55	18.69
60	22.00
65	26.00
70	30.20
75	34.70
80	39.50
100	61.70
110	74.60
115	81.50
120	88.00
125	96.30
130	104.00
135	112.00
140	121.00
145	130.00
150	139.00

Black Squares

EN10025-2 S275JR / S355JR

Size mm	kg/m
8	0.51
10	0.79
12	1.13
12.5	1.22
16	2.01
20	3.14
22	3.80
25	4.91
30	7.07
32	7.90
35	9.62
38	11.38
40	12.60
45	15.90
50	19.62
55	23.70
60	28.40
65	33.16
70	39.10
75	44.20
80	50.20
85	56.70
90	63.60
100	78.50

Square Hollow Section

Cold Formed Welded

EN10219-1 S235 JRH

Size mm	kg/m	Size mm	kg/m
20 x 20 x 2.0	1.12	70 x 70 x 3.0	6.28
20 x 20 x 2.5	1.35	70 x 70 x 3.6	7.46
25 x 25 x 1.5	1.06	70 x 70 x 5.0	10.11
25 x 25 x 2.0	1.43	75 x 75 x 3.0	7.07
25 x 25 x 2.5	1.74	80 x 80 x 3.0	7.22
25 x 25 x 3.0	2.04	80 x 80 x 3.6	8.59
30 x 30 x 2.0	1.68	80 x 80 x 5.0	11.70
30 x 30 x 2.5	2.14	80 x 80 x 6.0	13.90
30 x 30 x 3.0	2.51	90 x 90 x 3.0	8.01
40 x 40 x 1.5	1.81	90 x 90 x 3.6	9.72
40 x 40 x 2.0	2.31	90 x 90 x 5.0	13.30
40 x 40 x 2.5	2.92	90 x 90 x 6.0	15.76
40 x 40 x 3.0	3.45	100 x 100 x 3.0	8.96
40 x 40 x 4.0	4.46	100 x 100 x 4.0	12.00
45 x 45 x 1.5	2.00	100 x 100 x 5.0	14.80
50 x 50 x 1.5	2.28	120 x 60 x 3.6	9.72
50 x 50 x 2.0	2.93	120 x 60 x 5.0	13.30
50 x 50 x 2.5	3.71	120 x 120 x 5.0	18.00
50 x 50 x 3.0	4.39	120 x 120 x 6.0	21.30
50 x 50 x 4.0	5.72	150 x 150 x 5.0	22.70
50 x 50 x 5.0	6.97	150 x 150 x 6.0	27.00
60 x 60 x 3.0	5.34		
60 x 60 x 4.0	6.97		
60 x 60 x 5.0	8.54		
60 x 60 x 6.0	9.45		

Circular Hollow Section

Cold Formed Welded

EN10219-1 S235 JRH

Size mm	kg/m
26.9 x 2.0	1.23
26.9 x 2.5	1.50
26.9 x 3.0	1.87
33.7 x 2.0	1.56
33.7 x 2.5	1.92
33.7 x 3.0	2.27
33.7 x 4.0	2.93
42.4 x 2.5	2.46
42.4 x 3.0	2.91
42.4 x 3.6	3.44
42.4 x 4.0	3.79
48.3 x 2.5	2.82
48.3 x 3.0	3.35
48.3 x 3.6	3.97
48.3 x 4.0	4.37
60.3 x 2.5	3.56
60.3 x 3.0	4.24
60.3 x 3.6	5.75
60.3 x 4.0	5.55
76.1 x 2.5	4.54
76.1 x 3.0	5.41
76.1 x 3.63	6.44
76.1 x 4.0	7.11
76.1 x 5.0	8.77
88.9 x 3.0	6.36
88.9 x 4.0	8.38
88.9 x 5.0	10.30
114.3 x 3.0	8.23
114.3 x 3.6	9.83
114.3 x 4.0	10.90
114.3 x 4.5	12.19
114.3 x 5.0	13.50
114.3 x 6.0	16.80

Rectangular Hollow Section

Cold Formed Welded

EN10219-1 S235 JRH

Size mm	kg/m	Size mm	kg/m
40 x 20 x 1.5	1.33	80 x 50 x 3.0	5.66
40 x 20 x 2.0	1.68	80 x 50 x 4.0	7.34
40 x 25 x 1.5	1.44	90 x 50 x 3.0	6.28
40 x 25 x 2.0	1.89	90 x 50 x 3.6	7.46
50 x 20 x 2.0	1.99	90 x 50 x 5.0	10.11
50 x 25 x 1.5	1.68	100 x 50 x 2.5	5.63
50 x 25 x 2.0	2.21	100 x 50 x 3.0	6.75
50 x 25 x 2.5	2.72	100 x 50 x 4.0	8.86
50 x 25 x 3.0	3.22	100 x 50 x 5.0	10.90
50 x 30 x 1.5	1.83	100 x 60 x 3.0	7.22
50 x 30 x 2.5	2.92	100 x 60 x 3.6	8.59
50 x 30 x 3.0	3.45	100 x 60 x 5.0	11.70
50 x 30 x 4.0	4.46	120 x 80 x 2.5	7.65
50 x 34 x 2.0	2.49	120 x 80 x 3.0	9.03
50 x 40 x 3.0	3.77	120 x 80 x 4.0	12.00
60 x 30 x 3.0	3.77	120 x 80 x 5.0	14.80
60 x 40 x 2.0	2.93	200 x 100 x 5.0	22.7
60 x 40 x 2.5	3.71	200 x 100 x 6.0	27.00
60 x 40 x 3.0	4.39		
60 x 40 x 4.0	5.72		
80 x 40 x 2.5	4.26		
80 x 40 x 3.0	5.34		
80 x 40 x 4.0	6.97		
80 x 40 x 5.0	8.54		

Square Hollow Section

Cold Formed Welded

EN10219-1 S355 J2H

Size mm	kg/m	Size mm	kg/m
50 x 50 x 4.0	5.72	120 x 120 x 5.0	18.00
50 x 50 x 5.0	6.97	120 x 120 x 6.0	21.30
60 x 60 x 3.0	5.34	120 x 120 x 8.0	27.90
60 x 60 x 4.0	6.97	120 x 120 x 10.0	34.20
60 x 60 x 5.0	8.54	140 x 140 x 5.0	21.10
60 x 60 x 6.0	9.45	140 x 140 x 8.0	32.90
70 x 70 x 3.0	6.28	150 x 150 x 5.0	22.70
70 x 70 x 3.6	7.46	150 x 150 x 6.0	27.00
70 x 70 x 5.0	10.11	150 x 150 x 8.0	35.40
80 x 80 x 3.0	7.22	150 x 150 x 10.0	43.60
80 x 80 x 3.6	8.59	180 x 180 x 5.0	27.40
80 x 80 x 5.0	11.70	180 x 180 x 6.0	34.20
80 x 80 x 6.0	13.90	180 x 180 x 8.0	43.00
90 x 90 x 5.0	13.30	180 x 180 x 10.0	53.00
90 x 90 x 6.0	15.76	200 x 200 x 5.0	30.50
100 x 100 x 4.0	12.00	200 x 200 x 6.0	38.20
100 x 100 x 5.0	14.80	200 x 200 x 8.0	48.00
100 x 100 x 6.0	17.60	200 x 200 x 10.0	59.30
100 x 100 x 8.0	22.90	250 x 250 x 6.0	48.10
100 x 100 x 10	27.90	250 x 250 x 8.0	60.50
		250 x 250 x 10.0	75.00
		300 x 200 x 6.0	48.10
		300 x 200 x 8.0	60.50
		300 x 200 x 10.0	75.00
		300 x 300 x 8.0	73.10
		300 x 300 x 10.0	90.70

Rectangular Hollow Section

Cold Formed Welded

EN10219-1 S355 J2H

Size mm	kg/m
50 x 30 x 3.0	3.45
60 x 40 x 3.0	4.39
60 x 40 x 4.0	5.72
80 x 40 x 3.0	5.34
80 x 40 x 4.0	6.97
80 x 40 x 5.0	8.54
100 x 50 x 3.0	6.75
100 x 50 x 4.0	8.86
100 x 50 x 5.0	10.90
120 x 80 x 5.0	14.80
120 x 80 x 6.0	17.60
120 x 80 x 8.0	22.9
150 x 100 x 5.0	18.70
150 x 100 x 6.0	22.30
150 x 100 x 8.0	29.10
150 x 100 x 10.0	35.70
160 x 80 x 5.0	18.00
160 x 80 x 6.0	21.30
160 x 80 x 8.0	27.90
200 x 100 x 5.0	22.70
200 x 100 x 6.0	27.00
200 x 100 x 8.0	35.4
200 x 100 x 10.0	43.60
250 x 150 x 5.0	30.5
250 x 150 x 6.0	38.2
250 x 150 x 8.0	48.0
250 x 150 x 10	59.3
300 x 200 x 6.0	48.10
300 x 200 x 8.0	60.50
300 x 200 x 10.0	75.00
400 x 200 x 8.0	73.10
400 x 200 x 10.0	90.70

Circular Hollow Section

Cold Formed Welded
EN10219-1 S355 J2H

Size mm	kg/m	Size mm	kg/m	Size mm	kg/m
48.3 x 2.5	2.82	139.7 x 5.0	16.60	244.5 x 6.0	37.00
48.3 x 3.0	3.35	139.7 x 6.0	20.70	244.5 x 8.0	46.70
48.3 x 3.6	3.97	139.7 x 8.0	26.00	244.5 x 10.0	57.80
48.3 x 4.0	4.37	139.7 x 10.0	32.00		
				273.0 x 6.0	41.40
60.3 x 3.0	4.24	168.3 x 5.0	20.10	273.0 x 8.0	52.30
60.3 x 3.6	5.75	168.3 x 6.0	25.20	273.0 x 10.0	64.90
60.3 x 4.0	5.55	168.3 x 8.0	31.60	273.0 x 12.5	80.30
		168.3 x 10.0	39.00		
76.1 x 3.0	5.41			323.9 x 6.0	49.30
76.1 x 4.0	7.11	193.7 x 5.0	23.30	323.9 x 8.0	62.30
76.1 x 5.0	8.77	193.7 x 6.0	29.10	323.9 x 10.0	77.40
		193.7 x 8.0	36.60	323.9 x 12.5	96.00
		193.7 x 10.0	45.30		
88.9 x 3.0	6.36				
88.9 x 4.0	8.38	219.1 x 5.0	26.40		
88.9 x 5.0	10.30	219.1 x 6.0	33.10		
		219.1 x 8.0	41.60		
114.3 x 3.0	8.23	219.1 x 10.0	51.60		
114.3 x 3.6	9.83	219.1 x 12.5	63.70		
114.3 x 4.0	10.90				
114.3 x 5.0	13.50				
114.3 x 6.0	16.80				

Square Hollow Section

Hot Finished Welded

EN10210-1 S355 J2H

Size mm	kg/m	Size mm	kg/m	Size mm	kg/m
40 x 40 x 2.5	2.92	90 x 90 x 3.6	9.72	180 x 180 x 5.0	27.40
40 x 40 x 3.0	3.45	90 x 80 x 4.0	10.70	180 x 180 x 6.3	34.20
40 x 40 x 3.2	3.66	90 x 90 x 5.0	13.30	180 x 180 x 8.0	43.00
40 x 40 x 4.0	4.46	90 x 90 x 6.3	16.40	180 x 180 x 10.0	53.00
40 x 40 x 5.0	5.40	90 x 90 x 8.0	20.40	180 x 180 x 12.5	65.20
				180 x 180 x 16.0	81.40
50 x 50 x 2.5	3.71	100 x 100 x 4.0	12.00		
50 x 50 x 3.0	4.39	100 x 100 x 5.0	14.80	200 x 200 x 5.0	30.50
50 x 50 x 3.2	4.66	100 x 100 x 6.3	18.40	200 x 200 x 6.3	38.20
50 x 50 x 4.0	5.72	100 x 100 x 8.0	22.90	200 x 200 x 8.0	48.00
50 x 50 x 5.0	6.97	100 x 100 x 10.0	27.90	200 x 200 x 10.0	59.30
50 x 50 x 6.3	8.49	100 x 100 x 12.5	33.00	200 x 200 x 12.5	73.00
				200 x 200 x 16.0	91.50
60 x 60 x 3.0	5.34	120 x 120 x 4.0	14.40		
60 x 60 x 3.2	5.67	120 x 120 x 5.0	18.00	250 x 250 x 6.3	48.10
60 x 60 x 4.0	6.97	120 x 120 x 6.3	22.30	250 x 250 x 8.0	60.50
60 x 60 x 5.0	8.54	120 x 120 x 8.0	27.90	250 x 250 x 10.0	75.00
60 x 60 x 6.3	10.50	120 x 120 x 10.0	34.20	250 x 250 x 12.5	92.60
60 x 60 x 8.0	12.80	120 x 120 x 12.5	41.60	250 x 250 x 16.0	117.0
70 x 70 x 3.0	6.28	140 x 140 x 5.0	21.10	300 x 300 x 6.3	57.90
70 x 70 x 3.6	7.46	140 x 140 x 6.3	26.30	300 x 300 x 8.0	73.10
70 x 70 x 5.0	10.10	140 x 140 x 8.0	32.90	300 x 300 x 10.0	90.70
70 x 70 x 6.3	12.50	140 x 140 x 10.0	40.40	300 x 300 x 12.5	112.00
70 x 70 x 8.0	15.30	140 x 140 x 12.5	49.50	300 x 300 x 16.0	142.00
80 x 80 x 3.0	7.22	150 x 150 x 5.0	22.70	350 x 350 x 8.0	85.70
80 x 80 x 3.6	8.59	150 x 150 x 6.3	28.30	350 x 350 x 10.0	106.00
80 x 80 x 4.0	9.41	150 x 150 x 8.0	35.40	350 x 350 x 12.5	132.00
80 x 80 x 5.0	11.70	150 x 150 x 10.0	43.60	350 x 350 x 16.0	167.00
80 x 80 x 6.3	14.40	150 x 150 x 12.5	53.40		
80 x 80 x 8.0	17.80	150 x 150 x 16.0	65.17	400 x 400 x 8.0	98.00
80 x 80 x 10.0	21.14			400 x 400 x 10.0	122.00
				400 x 400 x 12.5	152.00
		160 x 160 x 5.0	24.20	400 x 400 x 16.0	192.00
		160 x 160 x 6.3	30.30	400 x 400 x 20.0	237.00
		160 x 160 x 8.0	37.90		
		160 x 160 x 10.0	46.70		
		160 x 160 x 12.5	57.30		
		160 x 160 x 16.0	70.20		

Rectangular Hollow Section

Hot Finished Welded

EN10210-1 S355 J2H

Size mm	kg/m	Size mm	kg/m	Size mm	kg/m
50 x 30 x 2.5	2.92	100 x 50 x 5.0	10.90	160 x 80 x 4.0	14.40
50 x 30 x 3.0	3.45	100 x 50 x 6.3	13.40	160 x 80 x 5.0	18.00
50 x 30 x 3.2	3.66	100 x 50 x 8.0	16.60	160 x 80 x 6.3	22.30
50 x 30 x 4.0	4.46	100 x 50 x 10.0	19.57	160 x 80 x 8.0	27.90
50 x 30 x 5.0	5.40			160 x 80 x 10.0	34.20
		100 x 60 x 3.0	7.22	160 x 80 x 12.5	41.60
60 x 40 x 2.5	3.71	100 x 60 x 3.6	8.59		
60 x 40 x 3.0	4.39	100 x 60 x 5.0	11.70	180 x 100 x 10	39.98
60 x 40 x 3.2	4.66	100 x 60 x 6.3	14.40		
60 x 40 x 4.0	5.72	100 x 60 x 8.0	17.80	200 x 100 x 5.0	22.70
60 x 40 x 5.0	6.97	100 x 60 x 10.0	21.14	200 x 100 x 6.3	28.30
60 x 40 x 6.3	8.49			200 x 100 x 8.0	35.40
		100 x 80 x 10.0	24.28	200 x 100 x 10.0	43.60
76.2 x 38.1 x 3.2	5.38			200 x 100 x 12.5	53.40
76.2 x 38.1 x 4.0	6.62	120 x 60 x 3.6	9.72	200 x 100 x 16.0	65.17
		120 x 60 x 5.0	13.30		
76.2 x 50.8 x 3.2	6.02	120 x 60 x 6.3	16.40	200 x 120 x 5.0	24.20
76.2 x 50.8 x 4.0	7.41	120 x 60 x 8.0	20.40	200 x 120 x 6.3	30.30
76.2 x 50.8 x 4.9	8.93	120 x 60 x 10.0	24.30	200 x 120 x 8.0	37.90
76.2 x 50.8 x 6.3	11.20			200 x 120 x 10.0	46.70
		120 x 80 x 5.0	14.80	200 x 120 x 12.5	57.30
80 x 40 x 3.0	5.29	120 x 80 x 6.3	18.40		
80 x 40 x 3.2	5.62	120 x 80 x 8.0	22.90	200 x 150 x 5.0	26.50
80 x 40 x 4.0	6.90	120 x 80 x 10.0	27.90	200 x 150 x 6.3	33.00
80 x 40 x 5.0	8.42	120 x 80 x 12.5	33.00	200 x 150 x 8.0	41.40
80 x 40 x 6.3	10.30			200 x 150 x 10.0	51.00
80 x 40 x 8.0	12.50	140 x 70 x 4.0	12.56	200 x 150 x 12.5	62.50
		150 x 100 x 4.0	15.10	250 x 100 x 5.0	26.50
90 x 50 x 3.0	6.28	150 x 100 x 5.0	18.70	250 x 100 x 6.3	33.00
90 x 50 x 3.6	7.46	150 x 100 x 6.3	23.30	250 x 100 x 8.0	41.40
90 x 50 x 5.0	10.10	150 x 100 x 8.0	29.10	250 x 100 x 10.0	51.00
90 x 50 x 6.3	12.50	150 x 100 x 10.0	35.70	250 x 100 x 12.5	62.50
90 x 50 x 8.0	15.30	150 x 100 x 12.5	43.60		
				250 x 150 x 5.0	30.50
100 x 50 x 3.0	6.75	152.4 x 76.2 x 4.9	16.70	250 x 150 x 6.3	38.20
100 x 50 x 3.2	7.18	152.4 x 76.2 x 6.3	21.20	250 x 150 x 8.0	48.00
100 x 50 x 4.0	8.86	152.4 x 76.2 x 9.5	30.90	250 x 150 x 10.0	59.30
				250 x 150 x 12.5	73.00
				250 x 150 x 16.0	91.50

Rectangular Hollow Section

Hot Finished Welded

EN10210-1 S355 J2H

Size mm	kg/m	Size mm	kg/m
260 x 140 x 6.3	38.00	400 x 200 x 6.3	57.80
260 x 140 x 8.0	47.70	400 x 200 x 8.0	73.10
260 x 140 x 10.0	58.80	400 x 200 x 10.0	90.70
260 x 140 x 12.5	72.30	400 x 200 x 12.5	112.00
		400 x 200 x 16.0	142.00
300 x 50 x 5.0	26.50		
		400 x 300 x 8.0	85.40
300 x 100 x 5.0	30.40	400 x 300 x 10.0	106.00
300 x 100 x 6.3	38.00	400 x 300 x 12.5	131.00
300 x 100 x 8.0	47.40	400 x 300 x 16.0	166.00
300 x 100 x 10.0	58.80		
300 x 100 x 12.5	72.30	450 x 250 x 8.0	85.70
		450 x 250 x 10.0	106.00
300 x 150 x 5.0	38.30	450 x 250 x 12.5	132.00
300 x 150 x 6.3	42.93	450 x 250 x 16.0	167.00
300 x 150 x 8.0	53.98		
300 x 150 x 10.0	66.70	500 x 200 x 8.0	85.70
300 x 150 x 12.5	82.10	500 x 200 x 10.0	106.00
		500 x 200 x 12.5	132.00
300 x 200 x 5.0	38.30	500 x 200 x 16.0	167.00
300 x 200 x 6.3	48.10		
300 x 200 x 8.0	60.50	500 x 300 x 8.0	98.00
300 x 200 x 10.0	75.00	500 x 300 x 10.0	122.00
300 x 200 x 12.5	92.60	500 x 300 x 12.5	152.00
300 x 200 x 16.0	117.00	500 x 300 x 16.0	192.00
		500 x 300 x 20.0	237.00
350 x 150 x 6.3	47.90		
350 x 150 x 8.0	60.30		
350 x 150 x 10.0	74.50		
350 x 150 x 12.5	91.90		
350 x 250 x 6.3	57.80		
350 x 250 x 8.0	72.80		
350 x 250 x 10.0	90.20		
350 x 250 x 12.5	112.00		
350 x 250 x 16.0	141.00		
400 x 100 x 10.0	74.50		
400 x 100 x 12.5	91.90		

Circular Hollow Section

Hot Finished Welded

EN10210-1 S355 J2H

Size mm	kg/m	Size mm	kg/m	Size mm	kg/m
21.3 x 3.2	1.43	114.3 x 8.0	20.97	273.0 x 10.0	64.90
26.9 x 3.2	1.87	114.3 x 10.0	25.72	273.0 x 12.5	80.30
33.7 x 2.6	1.99	139.7 x 5.0	16.60	273.0 x 16.0	101.00
33.7 x 3.2	2.41	139.7 x 6.3	20.70	323.9 x 5.0	39.30
33.7 x 4.0	2.93	139.7 x 8.0	26.00	323.9 x 6.3	49.30
42.4 x 2.6	2.55	139.7 x 10.0	32.00	323.9 x 8.0	62.30
42.4 x 3.2	3.09	168.3 x 5.0	20.10	323.9 x 10.0	77.40
42.4 x 4.0	3.79	168.3 x 6.3	25.20	323.0 x 12.5	96.00
48.3 x 3.2	3.56	168.3 x 8.0	31.60	323.0 x 16.0	121.00
48.3 x 4.0	4.37	168.3 x 10.0	39.00	355.6 x 6.3	54.30
48.3 x 5.0	5.34	168.3 x 12.5	48.00	355.6 x 8.0	68.60
60.3 x 3.2	4.51	193.7 x 5.0	23.30	355.6 x 10.0	85.20
60.3 x 4.0	5.55	193.7 x 6.3	29.10	355.6 x 12.5	106.00
60.3 x 5.0	6.82	193.7 x 8.0	36.60	355.6 x 16.0	134.00
76.1 x 3.2	5.75	193.7 x 10.0	45.30	406.4 x 6.3	62.30
76.1 x 4.0	7.11	193.7 x 12.5	55.90	406.4 x 8.0	78.60
76.1 x 5.0	8.77	219.1 x 5.0	26.40	406.4 x 10.0	97.80
76.1 x 10.0	16.30	219.1 x 6.3	33.10	406.4 x 12.5	121.00
88.9 x 3.2	6.76	219.1 x 8.0	41.60	406.4 x 16.0	174.00
88.9 x 4.0	8.38	219.1 x 10.0	51.60	457.0 x 10.0	110.00
88.9 x 5.0	10.30	219.1 x 12.5	63.70	457.0 x 12.5	137.00
88.9 x 6.3	12.80	219.1 x 16.0	80.10	457.0 x 16.0	154.00
101.6 x 6.3	14.81	244.5 x 5.0	29.50	508.0 x 10.0	123.00
114.3 x 3.6	9.83	244.5 x 6.3	37.00	508.0 x 12.5	153.00
114.3 x 4.0	10.88	244.5 x 8.0	46.70	508.0 x 16.0	194.00
114.3 x 5.0	13.50	244.5 x 10.0	57.80	508.0 x 20.0	241.00
114.3 x 6.3	16.80	244.5 x 12.5	71.50		
114.3 x 8.0	20.97	244.5 x 16.0	90.20		
114.3 x 10.0	25.72	273.0 x 5.0	33.00		
		273.0 x 6.3	41.40		
		273.0 x 8.0	52.30		

Flat Products

Hot Rolled

EN 10025-2-2004 S275JR

Thickness mm	Size mm
● 1.6	2000 x 1000 2500 x 1250
● 2.0	2000 x 1000 2500 x 1250 3000 x 1500
● 2.5	2500 x 1250 3000 x 1500
3	2000 x 1000 2500 x 1250 3000 x 1500 4000 x 2000
4	2000 x 1000 2500 x 1250 3000 x 1500 4000 x 2000
5	2000 x 1000 2500 x 1250 3000 x 1500 4000 x 2000
6	2000 x 1000 2500 x 1250 3000 x 1500 4000 x 2000
8	2000 x 1000 2500 x 1250 3000 x 1500 4000 x 2000
10	2000 x 1000 2500 x 1250 3000 x 1500 4000 x 2000 2000 x 1000 2500 x 1250 3000 x 1500
12	2000 x 1000 2500 x 1250 3000 x 1500
12.5	2000 x 1000 2500 x 1250 3000 x 1500 4000 x 2000

Flat Products

Floor Plate

EN 10025-2-2004 S275JR

Thickness mm	Size mm
3	2000 x 1000 2500 x 1250
4.5	2000 x 1000 2500 x 1250 3000 x 1500
6	2000 x 1000 2500 x 1250 3000 x 1500 4000 x 1830
8	2000 x 1000 2500 x 1250 3000 x 1500
10	2000 x 1000 2500 x 1250 3000 x 1500
12.5	2500 x 1250

- **Please note: These items are available in DD11 EN 10111:2008**

Flat Products

Cold Reduced

EN 10130: 2006 DC01

Thickness mm	Size mm
1.0	2500 x 1250
1.2	2000 x 1000 2500 x 1250
1.5	2000 x 1000 2500 x 1250
2.0	2000 x 1000 2500 x 1250 3000 x 1500
2.5	2500 x 1250

Galvanised

EN 10346:2009 DX51D

Thickness mm	Size mm
0.5	2500 x 1250
0.7	2500 x 1250 3000 x 1250
0.8	3000 x 1500
0.9	2500 x 1250
1.0	2500 x 1250 3000 x 1500
1.2	2500 x 1250 3000 x 1500
1.5	2500 x 1250 3000 x 1500
1.6	2500 x 1250
2.0	2000 x 1000 2500 x 1250 3000 x 1500
3.0	2000 x 1000 2500 x 1250 3000 x 1500

Electro-Zinc (Zintec)

EN 10152:2009 DC01 ZE 25/25

Thickness mm	Size mm
0.9	2500 x 1250
1.2	2500 x 1250
1.5	2500 x 1250 3000 x 1500
2.0	2500 x 1250 3000 x 1500 3000 x 1500
3.0	2500 x 1250

Aluzinc

DX51D + AZ185 AFP

Thickness mm	Size mm
0.5	2000 x 1000
0.6	2000 x 1000
0.7	2000 x 1000
0.9	2000 x 1000

Aluzinc

DX51D + AZ150 AFP

Thickness mm	Size mm
1.0	2500 x 1250

Aluzinc

DX51D + AZ150

Thickness mm	Size mm
1.2	2500 x 1250
1.5	2500 x 1250
2.0	2500 x 1250

Reversing Mill Plate

Structural grades

EN10025:2005 S275JR / S355J2+N

Thickness mm	Size mm	Thickness mm	Size mm	Thickness mm	Size mm
5	10000 x 2500	25	2000 x 1000 2500 x 1250 3000 x 1500 4000 x 2000 5000 x 2500 10000 x 2500 12000 x 3000	50	4000 x 2000 5000 x 2500 10000 x 2500 12000 x 3000
6	10000 x 2500 12000 x 3000				
8	10000 x 2500 12000 x 3000	30	2000 x 1000 2500 x 1250 3000 x 1500 4000 x 2000 5000 x 2500 10000 x 2500 12000 x 3000	55	4000 x 2000
10	4000 x 2000 5000 x 2500 12000 x 3000			60	4000 x 2000 5000 x 2500
12.5	4000 x 2000 5000 x 2500 12000 x 3000	35	4000 x 2000 5000 x 2500 10000 x 2500 12000 x 3000	65	4000 x 2000
15	2000 x 1000 2500 x 1250 3000 x 1500 4000 x 2000 5000 x 2500 10000 x 2500 12000 x 3000			70	4000 x 2000 5000 x 2500
20	2000 x 1000 2500 x 1250 3000 x 1500 4000 x 2000 5000 x 2500 10000 x 2500 12000 x 3000	40	4000 x 2000 5000 x 2500 10000 x 2500 12000 x 3000	75	4000 x 2000
				80	4000 x 2000
		45	4000 x 2000 5000 x 2500 10000 x 2500 12000 x 3000	90	4000 x 2000
				100	4000 x 2000

Reversing Mill Plate

Boiler Plate

EN 10028:Part 2:2009:P265GH

Thickness mm	Size (Length x width)	Thickness mm	Size (Length x width)	Thickness mm	Size (Length x width)	
6	2500 x 12000	20	2000 x 12000	50	2055 x 8000	
	3000 x 12000		2500 x 12000		2500 x 12000	
	2000 x 12000		3000 x 12000		3000 x 12000	
8	2000 x 12000	22	3460 x 14000	55	3000 x 6000	
	2500 x 12000		4000 x 12000		60	3000 x 6000
	3000 x 12000		25			2000 x 12000
10	2000 x 12000	30		2500 x 12000	70	3000 x 6000
	2500 x 12000		3000 x 12000	75		3000 x 6000
	3000 x 12000		35			2000 x 12000
12.5	2000 x 12000	40		2500 x 12000	85	3000 x 6000
	2500 x 12000		3000 x 12000	90		3000 x 6000
	3000 x 12000		4000 x 12000			100
	3460 x 14000		45	2000 x 12000		
4000 x 12000	2500 x 12000					
13	2000 x 12000	50	3000 x 12000	3000 x 6000		
	2500 x 12000		2000 x 12000			
	3000 x 12000		2500 x 12000			
	3460 x 14000		3000 x 12000			
15	4000 x 12000	60	2000 x 12000	3000 x 6000		
	2000 x 12000		2500 x 12000			
	2500 x 12000		3000 x 12000			
	3000 x 12000		3460 x 14000			
16	3460 x 14000	70	4000 x 12000	3000 x 6000		
	2000 x 12000		2000 x 12000			
	2500 x 12000		2500 x 12000			
	3000 x 12000		3000 x 12000			
16	4000 x 12000	80	2000 x 12000	3000 x 6000		
	2000 x 12000		2500 x 12000			
	2500 x 12000		3000 x 12000			
	3000 x 12000		4000 x 12000			

Reversing Mill Plate

Multi – Certified Pressure Vessel Plate

Thickness mm	Size (Length x width)	Thickness mm	Size (Length x width)	Thickness mm	Size (Length x width)	
6	2000 x 12000	25	2000 x 12000	65	3000 x 6000	
	2500 x 12000		2500 x 12000		70	3000 x 6000
	3000 x 12000		3000 x 12000	75	3000 x 6000	
8	2000 x 12000	30	2500 x 12000		3000 x 6000	
	2500 x 12000		3000 x 12000		80	2500 x 6000
	3000 x 12000		3460 x 14000		90	3000 x 6000
10	2000 x 12000	35	2000 x 12000	100		3000 x 6000
	2500 x 12000		3000 x 12000		3000 x 10000	
	3000 x 12000		40		2000 x 12000	
13	2000 x 12000	2500 x 12000				
	2500 x 12000	3000 x 12000				
	3000 x 12000	45	2500 x 12000			
3460 x 14000	3000 x 12000					
16	2000 x 12000	50	2500 x 12000			
	2500 x 12000		3000 x 12000			
20	2000 x 12000	55	3000 x 6000			
	2500 x 12000		60	3000 x 6000		
	3000 x 12000					
	3460 x 14000					

ASD's Pressure Vessel Plate is dual certified to the following standards;

EN 10028 Part 3 2009 P355NL1/NL2

ASTM A516 Grades 60, 65 & 70

ASME SA.516 Grades 60, 65 & 70

BS 1501-161 Grade 430B

BS 1501-224 Grade 490BLT50

Reversing Mill Plate

Abrasion Resistant Plate

400HBW

Thickness mm	Size (Length x width)	Thickness mm	Size (Length x width)	Thickness mm	Size (Length x width)
5	1500 x 3000	20	2000 x 12000 2500 x 12000 3000 x 12000	45	2500 x 10000 3000 x 9000
6	1500 x 3000 2500 x 6000				
8	2000 x 6000 3000 x 6000			25	2000 x 12000 2500 x 12000 3000 x 12000
		10	2000 x 12000 2500 x 12000 3000 x 12000		
12	2000 x 12000 2500 x 12000 3000 x 12000	30	2000 x 12000 2500 x 12000 3000 x 6000 3000 x 12000		
				15	2000 x 12000 2500 x 12000 3000 x 12000
		40	2000 x 12000 2500 x 12000 3000 x 6000 3000 x 12000	65	2000 x 4000
				70	3000 x 6000
				80	3000 x 6000

Reversing Mill Plate

High Strength

EN 10025:Part 6:2004:S690QL

Thickness mm	Size (Length x width)	Thickness mm	Size (Length x width)	Thickness mm	Size (Length x width)
8	2500 x 12000 3000 x 12000	20	2000 x 12000 2500 x 12000 3000 x 12000	40	2000 x 12000 2500 x 12000 3000 x 12000
12	2000 x 12000 2500 x 12000 3000 x 12000			25	2000 x 12000 2500 x 12000 3000 x 12000
		12.5	3000 x 12000		
15	2000 x 12000 2500 x 12000 3000 x 12000	30	2000 x 12000 2500 x 12000 3000 x 12000	50	2000 x 12000 2500 x 12000 3000 x 12000
		35	2000 x 12000 2500 x 10000 3000 x 10000	60	3000 x 6000
				65	2000 x 4000
				70	3000 x 6000
				80	3000 x 6000
				90	3000 x 6000
				100	3000 x 6000

COR-TEN

High strength, low alloy, weldable structural steel. Steel that protects itself.

Cor-ten is a high strength, low alloy, weldable structural steel possessing excellent weathering resistance. It may be used to advantage in painted or unpainted condition. The steel owes its weathering resistance to the formation of a protective oxide coating which seals the surface against further corrosion. The coating is of a dark brown appearance and if chipped or damaged, repairs itself to give continuity of protection and appearance.

Cor-ten is recommended for use where high structural strength is needed and where maintenance is difficult. With mechanical properties similar to conventional steels, Cor-ten can be used to construct lighter structures utilising well-established design practices but with the advantage of improved weathering properties.

- Develops its own protective film which slows the rate of corrosion.
- Saves the cost of initial painting and the maintenance costs of repainting.
- Gives corrosion protection to unpainted areas which have been damaged. Painted areas which have been damaged will weather to form a protective film; this will extend to the edges of those areas and reduce under-paint corrosion 'creep'.

Literature providing more detailed information about the properties and applications of Cor-ten and technical guidance on welding, galvanising, cold bending and fabrication is available on request.

Available from:

0.8mm - 40mm thick

3.0mm - 40mm Material is dual certified to S355J2W & Cor-ten

Typical applications

Bridges, tanks and containers, exhaust systems, rail and road vehicles, windshields on chimneys, power station precipitators, rainscreen cladding, garden edging, firepits and art sculptures.

The trademark Cor-ten is used under licence from the USX Corporation, USA.



Electric Resistance Welded Tube (ERW) Circular

EN 10305:2010 PART 3 E220

Product Size	kg/m	Product Size	kg/m	Product Size	kg/m
10 x 1	0.222	22.2 x 1.5	0.770	40 x 1.5	1.424
10 x 1.5	0.314	22.2 x 2	1.001	40 x 2	1.874
12 x 1.5	0.388	22.2 x 2.5	1.220	41.3 x 1.2	1.178
12.7 x 0.9	0.262	25 x 1.5	0.869	41.3 x 1.5	1.462
12.7 x 1.2	0.341	25 x 2	1.13	44.5 x 1.2	1.282
12.7 x 1.5	0.414	25.4 x 0.9	0.544	44.5 x 1.5	1.591
12.7 x 2	0.528	25.4 x 1.2	0.716	44.5 x 2	2.097
15 x 1.5	0.499	25.4 x 1.5	0.884	44.5 x 3.2	3.284
15.9 x 0.9	0.329	25.4 x 1.5 Pregalv	0.884	48 x 2	2.270
15.9 x 1.2	0.430	25.4 x 1.5 Flocoat	0.884	50 x 1.5	1.790
15.9 x 1.5	0.528	25.4 x 1.6 True	0.939	50 x 2	2.370
15.9 x 1.5 Flocoat	0.528	25.4 x 2	1.154	50.8 x 1.2	1.470
15.9 x 2	0.693	25.4 x 2.5	1.412	50.8 x 1.5	1.824
16 x 2	0.691	25.4 x 3.2	1.776	50.8 x 2	2.410
18 x 1	0.419	28.6 x 1.2	0.811	50.8 x 2.5	2.980
18 x 2	0.789	28.6 x 1.5	1.003	50.8 x 3.2	3.787
19.05 x 0.9	0.401	28.6 x 2	1.313	57.1 x 1.5	2.050
19.05 x 0.9 Contiflo	0.401	30 x 1.5	1.050	60 x 2	2.860
19.05 x 0.9 Pregalv	0.401	30 x 2	1.380	60 x 3	4.220
19.05 x 1.02	0.444	31.8 x 1.2	0.904	63.5 x 1.5	2.293
19.05 x 1.2	0.527	31.8 x 1.5	1.117	63.5 x 2	3.032
19.05 x 1.5	0.647	31.8 x 2	1.465	63.5 x 3.2	4.793
19.05 x 1.5 Pregalv	0.647	31.8 x 2 Pregalv	1.465	70 x 1.5	2.530
19.05 x 2	0.687	31.8 x 2.5	1.795	76.1 x 1.5	2.760
19.05 x 2.5	0.838	31.8 x 3.2	2.300	76.1 x 2	3.652
20 x 1.2	0.556	34.9 x 1.2	1.000	76.1 x 3.2	5.788
20 x 1.5	0.684	34.9 x 1.5	1.240	101.6 x 1.5	3.700
20 x 2	0.888	34.9 x 2	1.630	101.6 x 3	7.29
22.2 x 1	0.525	35 x 2	1.630	101.6 x 3.6	8.808
22.2 x 1.2	0.625	38.1 x 1.2	1.090	127 x 2	6.170
22.2 x 1.22 Flocoat	0.625	38.1 x 1.5	1.354	127 x 3.2	9.811
22.2 x 1.2 Pregalv	0.625	38.1 x 2	1.781	152.4 x 3	10.700
		38.1 x 2.5	2.195		
		38.1 x 3.2	2.771		

Electric Resistance Welded Tube (ERW) Flat Side Oval

EN 10305:2010 PART 5 E220

Product Size	kg/m
25 x 12 x 1.5	0.695
30 x 15 x 1.5	0.869
31.8 x 15.8 x 1.5	0.914
40 x 20 x 1.5	1.16
40 x 20 x 2	1.52
50 x 25 x 1.5	1.49
60 x 30 x 1.5	1.79
60 x 30 x 2	2.37

Electric Resistance Welded Tube (ERW) Squares & Rectangles

EN 10305:2010 PART 5 E220

Product Size	kg/m	Product Size	kg/m	Product Size	kg/m
12.7 x 12.7 x 1.2	0.438	30 x 20 x 1.2	0.894	50 x 20 x 1.5	1.574
12.7 x 12.7 x 1.5	0.536	30 x 20 x 1.5	1.120	50 x 20 x 2	2.066
15.9 x 15.9 x 1.2	0.556	30 x 20 x 2	1.480	50 x 25 x 1.5	1.720
15.9 x 15.9 x 1.5	0.684	30 x 30 x 1.2	1.083	50 x 25 x 2	2.270
15.9 x 15.9 x 2	0.888	30 x 30 x 1.5	1.350	50 x 25 x 3	3.098
15.9 x 15.9 x 1.22 Pregalv	0.556	30 x 30 x 2	1.780	50 x 30 x 1.5	1.790
16 x 16 x 1.5	0.684	30 x 30 x 2.5	2.148	50 x 30 x 2	2.370
19.05 x 19.05 x 1.2	0.675	31.8 x 31.8 x 1.2	1.150	50 x 40 x 2	2.066
19.05 x 19.05 x 1.5	0.832	31.8 x 31.8 x 1.5	1.420	50 x 50 x 1.5	2.270
19.05 x 19.05 x 2	1.080	31.8 x 31.8 x 2	1.870	50 x 50 x 2	3.010
20 x 10 x 1.5	0.647	34.9 x 15.9 x 1.2	0.912	50 x 50 x 3	4.276
20 x 20 x 1.5	0.869	34.9 x 15.9 x 1.5	1.120	50.8 x 25.4 x 1.2	1.380
20 x 20 x 2	1.130	35 x 25 x 1.5	1.350	50.8 x 25.4 x 1.5	1.720
22 x 22 x 1.2	0.793	35 x 35 x 2	2.120	50.8 x 25.4 x 2	2.770
22.2 x 22.2 x 1.2	0.793	38.1 x 12.7 x 1.5	1.130	50.8 x 50.8 x 1.5	2.270
22.2 x 22.2 x 1.5	0.980	38.1 x 19.05 x 1.2	1.030	50.8 x 50.8 x 2	3.010
22.2 x 22.2 x 2	1.280	38.1 x 19.05 x 1.5	1.270	50.8 x 50.8 x 3.2	4.650
25 x 10 x 1.5	0.758	38.1 x 19.05 x 2	1.670	60 x 20 x 1.5	1.790
25.4 x 12.7 x 1.2	0.675	38.1 x 38.1 x 1.2	1.39	60 x 20 x 2	2.370
25.4 x 12.7 x 1.5	0.832	38.1 x 38.1 x 1.5	1.72	60 x 30 x 1.5	2.050
25 x 15 x 2	0.967	38.1 x 38.1 x 2	2.27	60 x 30 x 2	2.710
25 x 15 x 1.5	0.869	38.1 x 38.1 x 2.5	2.78	60 x 30 x 2.5	3.360
25 x 25 x 1.5	1.120	40 x 10 x 1.5	1.120	60 x 40 x 1.5	2.281
25 x 25 x 2	1.480	40 x 15 x 1.5	1.240	60 x 40 x 2	3.010
25.4 x 12.7 x 1.2	0.675	40 x 20 x 1.2	1.090	60 x 40 x 2.5	3.730
25.4 x 12.7 x 1.5	0.832	40 x 20 x 1.5	1.350	60 x 60 x 2	3.643
25.4 x 25.4 x 1.2	0.912	40 x 20 x 2	1.780	60 x 60 x 2.5	4.532
25.4 x 25.4 x 1.2 Pregalv	0.912	40 x 20 x 3	2.390	63.5 x 38.1 x 1.5	2.350
25.4 x 25.4 x 1.5	1.122	40 x 25 x 1.2	1.177	70 x 70 x 2	4.270
25.4 x 25.4 x 2	1.480	40 x 25 x 2	1.909	75 x 25 x 1.5	2.160
25.4 x 25.4 x 2.5	1.810	40 x 25 x 2.5	1.790	75 x 25 x 3	4.476
28.6 x 28.6 x 1.2	1.030	40 x 40 x 1.5	1.790	80 x 40 x 2	3.500
28.6 x 28.6 x 1.5	1.264	40 x 40 x 1.5 Pregalv	1.790	80 x 30 x 2.5	4.160
30 x 10 x 1.5	0.869	40 x 40 x 1.5 Marcecoat	1.790	80 x 80 x 2	4.288
30 x 15 x 1.5	0.980	40 x 40 x 2	2.370	100 x 30 x 2	5.690
		40 x 40 x 2.5	2.930	100 x 30 x 2.5	4.900
		40 x 40 x 2.5 Marcecoat	2.930	100 x 30 x 3	5.690
		45 x 15 x 1.5	1.350	100 x 40 x 2	4.270
		45 x 45 x 2	2.710	100 x 50 x 2	4.580
				100 x 100 x 2	6.150
				110 x 30 x 2.5	5.288

Tubes & Fittings

Flat Sided Oval

Size mm	kg/m
20 x 10 x 1.5	0.536
25 x 12 x 1.5	0.695
30 x 15 x 1.5	0.869
31.8 x 15.9 x 1.5	0.900
31.8 x 15.9 x 2	1.190
35 x 15 x 2	1.283
35 x 20 x 1.5	1.054
35 x 20 x 2	1.381
38 x 20 x 1.22	0.912
40 x 20 x 1.5	1.160
40 x 20 x 2	1.520
40 x 25 x 2	1.629
50 x 20 x 2	1.875
50 x 25 x 1.5	1.490
60 x 30 x 2	2.370
60 x 30 x 2.5	2.930

BS 1387 Tube

Light

Normal Bore		kg/m	Outside Dia.				Thickness	
in	mm		Max		Min		in	mm
1/2	15	0.947	0.843	21.4	0.827	21.0	0.079	2.0
3/4	20	1.38	1.059	26.9	1.039	26.4	0.091	2.3
1	25	1.98	1.331	33.8	1.307	33.2	0.102	2.6
1 1/4	32	2.54	1.673	42.5	1.650	41.9	0.102	2.6
1 1/2	40	3.23	1.906	48.4	1.882	47.8	0.114	2.9
2	50	4.08	2.370	60.2	2.346	59.6	0.114	2.9
2 1/2	65	5.71	2.992	76.0	2.961	75.2	0.126	3.2
3	80	6.72	3.492	88.7	3.461	87.9	0.126	3.2
4	100	9.75	4.484	113.9	4.449	113.0	0.142	3.6

Medium

Normal Bore		kg/m	Outside Dia.				Thickness	
in	mm		Max		Min		in	mm
1/4	8	0.641	0.547	13.9	0.524	13.3	0.091	2.3
3/8	10	0.839	0.685	17.4	0.661	16.8	0.091	2.3
1/2	15	1.21	0.854	21.7	0.831	21.1	0.102	2.6
3/4	20	1.56	1.071	27.2	1.047	26.6	0.102	2.6
1	25	2.41	1.346	34.2	1.315	33.4	0.126	3.2
1 1/4	32	3.10	1.689	42.9	1.657	42.1	0.126	3.2
1 1/2	40	3.57	1.921	48.8	1.890	48.0	0.126	3.2
2	50	5.03	2.394	60.8	2.354	59.8	0.142	3.6
2 1/2	65	6.43	3.016	76.6	2.968	75.4	0.142	3.6
3	80	8.37	3.524	89.5	3.468	88.1	0.157	4.0
4	100	12.2	4.524	114.9	4.461	113.3	0.177	4.5
5	125	16.6	5.535	140.6	5.461	138.7	0.197	5.0
6	150	19.7	6.539	166.1	6.461	164.1	0.197	5.0

Heavy

Normal Bore		kg/m	Outside Dia.				Thickness	
in	mm		Max		Min		in	mm
1/2	15	1.44	0.854	21.7	0.831	21.1	0.126	3.2
3/4	20	1.87	1.071	27.2	1.047	26.6	0.126	3.2
1	25	2.94	1.346	34.2	1.315	33.4	0.157	4.0
1 1/4	32	3.80	1.689	42.9	1.657	42.1	0.157	4.0
1 1/2	40	4.38	1.921	48.8	1.890	48.0	0.157	4.0
2	50	6.19	2.394	60.8	2.354	59.8	0.177	4.5
2 1/2	65	7.93	3.016	76.6	2.968	75.4	0.177	4.5
3	80	10.3	3.524	89.5	3.468	88.1	0.197	5.0
4	100	14.5	4.524	114.9	4.461	113.3	0.213	5.4
5	125	17.9	4.118	104.6	5.461	138.7	0.213	5.4
6	150	21.3	6.539	166.1	6.461	164.1	0.213	5.4

Available in self colour, galvanised, or red primer painted.
Plain end or screwed and socketed.
See next pages for details of Handrails & Klamps

Klamps

Type	Inside (Dia)	Outside (Dia)
A	$\frac{3}{4}$ "	$1\frac{1}{16}$ "
B	1"	$1\frac{11}{32}$ "
C	$1\frac{1}{4}$ "	$1\frac{11}{16}$ "
D	$1\frac{1}{2}$ "	$1\frac{29}{32}$ "
E	2"	$1\frac{3}{8}$ "

Tube Size	Tubeclamp	Tube Trade	Keeclamp
20mm NB/26.9 OD	A	1	5
25mm NB/33.79 OD	B	2	6
32mm NB/42.4 OD	C	3	7
40mm NB/48.3 OD	D	4	8
50mm NB/60.3 OD	E	5	

Klamps



Type 101

Short Tee

A E
B
C
D



40°-70°

Type 123

Variable Elbow

D

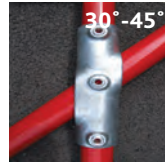

30°-45°

Type 130

Two Socket
Cross

B
C
D



Type 101

Reducing Tee

C/B E/D
D/B B/C
D/C C/D

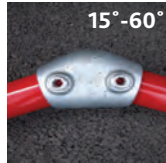

15°-60°

Type 124

Variable Elbow

B
C
D



Type 131

Base Flange

A E
B
C
D



Type 104

Long Tee

A E
B
C
D



Type 125

90° Elbow

A E
B
C
D



Type 132

Railing Base
Flange

A C E
B D



Type 116

Corner

A E
B
C
D



30°-45°

Type 127

Angle Tee

B
C
D



Type 133

Stop Ends
(Plastic)

A C E
B D



Type 119

Two Socket
Cross

A D
B E
C

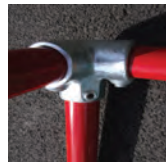

Type 128

3 Way 90°
Elbow

A D
B E
C



Type 134

Ground Socket

B
C
D



Type 119

Reducing
Cross

C/D

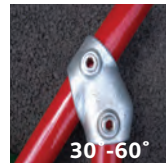

30°-60°

Type 129

Adjustable
Short Tee

B
C
D

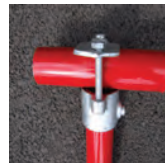

Type 135

Clamp on Tee

A D
B E
C

Klamps



Type 136
Clamp-On Tee
C
D

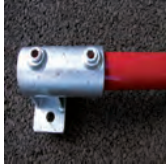

Type 145
Railing Side Support
B



Type 152
Slope Base Flange
B
C
D



Type 137
Clamp-On Crossover
D



Type 146
Side-Palm Fixing
B D
C



Type 153
Slope Short Tee
B D
C



Type 138
Gate Eye
A
B
C
D



Type 147
Internal Swivel Tee
B
C
D



Type 154
Elbow
B
C
D



Type 140
Gate Hinge
A D
B
C



Type 148*
Short Tee Swivel
A D
B E
C



Type 155
Slope Long Tee
B
C
D



Type 143
Handrail Bracket
A C
B D

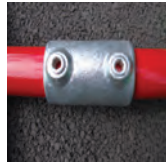

Type 149
Sleeve Joint
A D
B E
C

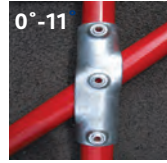

Type 156
Slope 2 Socket Cross
B D
C



Type 144
Railing Side Support
B
C
D



Type 150
Internal Joint
B
C
D



Type 158
Four Way Cross
A D
B E
C

Klamps



Type 160
Clamp on
Crossover
A D
B E
C



Type 167M
Double Male
Section of Swivel
AM DM
BM EM
CM



Type 171
Mesh Panel
Clip
A D
B E
C



Type 161
90° Crossover
A E
B or B/C
C
D



Type 168M
90° Corner Swivel
Male Section
AM DM
BM EM
CM



Type 173M
Single Male
Section of Swivel
AM DM
BM EM
CM



Type 161
Reducing
Crossover
C/B D/C
D/B E/D



Type 168
90° Corner Swivel
Combination
A D
B
C



Type 173F
Female Section
of Swivel
AF DF
BF EF
CF



Type 165
Combination
Socket
A D
B E
C



Type 169M
Swivel Base
Section
M



Type 173
Single Swivel
Combination
A D
B E
C



Type 166
Adjustable
Knuckle
B D
C E



Type 169
Swivel Base
A
B
C



Type 174
Swivel Tee
D

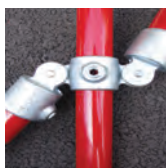

Type 167
Double Swivel
Combination
A D
B E
C

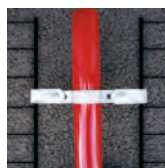

Type 170
Mesh Panel
Clip
A D
B E
C



Type 174M
Swivel Tee
Male Part
D

Klamps



Type 175
Swivel Elbow
D



Type 191
27 $\frac{1}{2}$ ° Ridge
Fitting
D



Type 333*
Aluminium
End Cap
A C E
B D



Type 175M
Swivel Elbow
Male Part
D



Type 192
Base Flange
B
C
D

* Illustration shows 2 fittings



Type 176
Side Outlet
Tee
A B C D E



Type 199
Adjustable
Fixing Bracket
D



Type 179
Locking Collar
A B C D E



Type 231
Extra Set Screws
Hexagon Recessed
To Suit:
A C E
B D



Type 182
Hook
A B C D



Type 232
Keys
Hexagon Key
To Suit:
A C E
B D

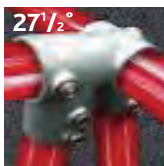

Type 185
27 $\frac{1}{2}$ ° Eeyes
Fitting
D



Type 233
Ratchet
Ratchet with Bit
To Suit:
A C E
B D

Handrail Standards

Type 1A Type 2B Type 3C Type 4D

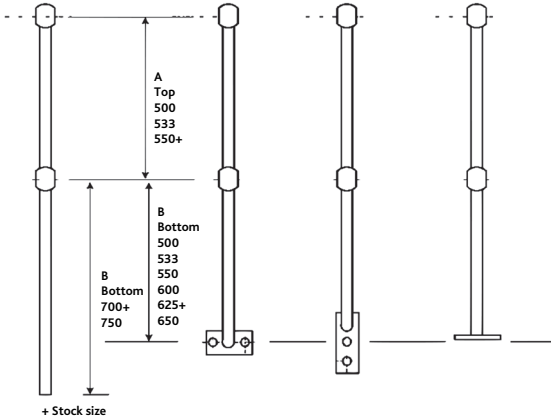

Type 5B* Type 6C* Type 7D Type 8D Type 9A

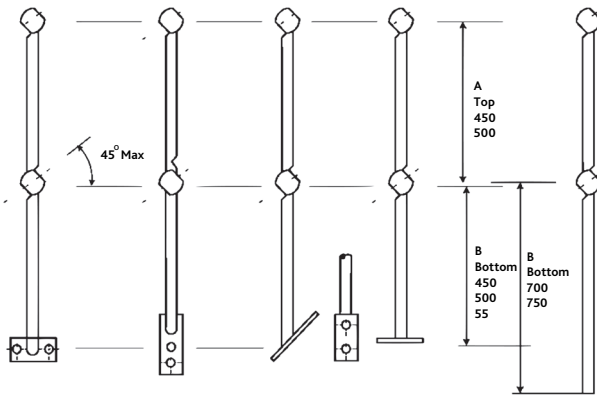

*Types 5B & 6C are handed L.H. or R.H. as ascending stairs.
 Dimensions A & B are for guide purposes only.
 Other sizes are available to suit your application.
 All Base Plates are drilled 18mm Dia.

Handrail Standards (Tubular)

Stock Availability

Tubular Handrail Standards are available to the following specifications.

25mm NB shank (33.7 O.D.)

with a 62mm ball to take 25mm NB handrail tube.

32mm NB shank (42.4 O.D.)

with a 76mm ball to take 32mm NB handrail tube.

32mm NB shank (42.4 O.D.)

with a 62mm ball to take 25mm NB handrail tube.

40mm NB shank (48.3 O.D.)

with a 76mm ball to take 32mm NB handrail tube.

40mm NB shank (48.3 O.D.)

with a 76mm ball to take 40mm NB handrail tube.

40mm NB shank (48.3 O.D.)

with a 90mm ball to take 40mm NB handrail tube.

Finish

Handrails can be supplied in the following finishes.

- 1) Self Colour,
- 2) Vented - prepared for galvanising (Tubular only),
- 3) Red oxide metal primer,
- 4) Hot dipped galvanised to BS EN ISO 1461, for corrosive and exposed areas.

Tubular Handrail Balls

25mm N.B. (62mm O.D.)

32mm N.B. (76mm O.D.)

40mm N.B. (76mm O.D.)

40mm N.B. (90mm O.D.)

Handrail Standards (Tubular)

Crimp Connectors

90° connector to suit 25mm N.B.

Straight connectors to suit 25mm N.B.

Wall palm connectors to suit 25mm N.B.



90° Dimpled Connector

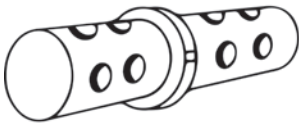

Straight Dimpled Connector

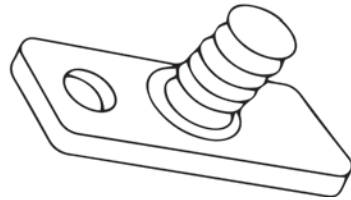

Wall Palm Connector

Crimping Tool

to suit 25mm N.B. Gas Tube

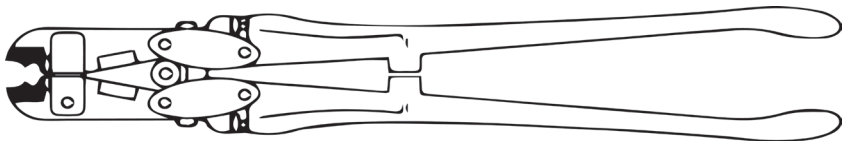

Handrail Standards (Tubular)

Handrail Bends

We offer the ultimate in handrail bends with Platform return bends, Angle bends, Ramp bends & Stair return bends. We also offer Wreath bends left & right hand and Dual left & right.

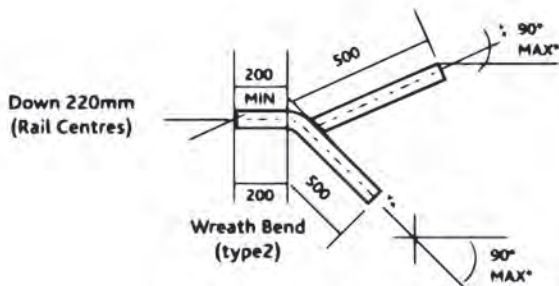
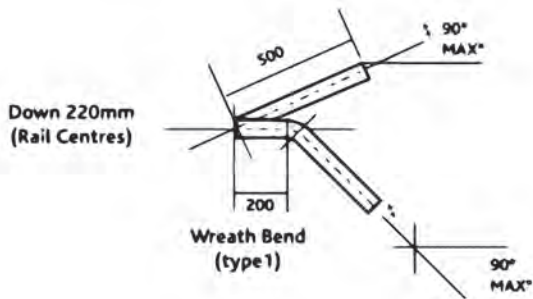
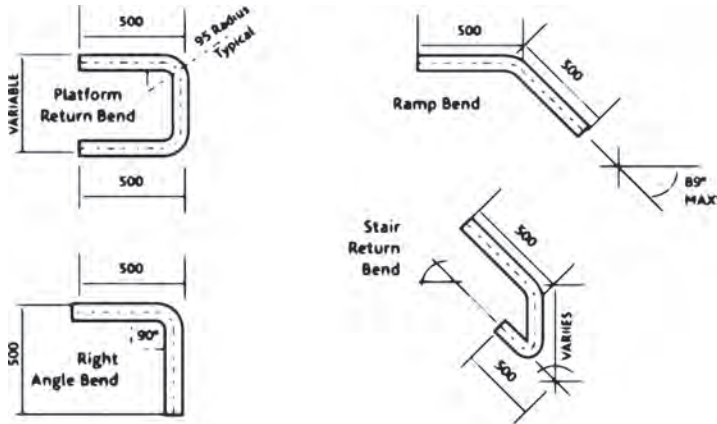

Flooring

Self Colour & Galvanised

Section mm	Type			
	41/100 kg/m	41/50 kg/m	30/100 kg/m	30/50 kg/m
20 x 3	13.44	15.25	17.70	19.50
25 x 3	16.39	18.19	21.64	23.44
30 x 3	19.34	21.14	25.73	27.54
40 x 3	25.25	27.05	33.61	35.40
20 x 5	21.31	23.11	28.36	30.16
25 x 5	26.22	28.03	35.08	36.88
30 x 5	31.15	32.95	41.63	43.44
35 x 5	36.06	37.87	48.36	50.16
40 x 5	40.98	42.78	55.08	56.88
45 x 5	45.90	47.70	61.64	63.44
50 x 5	50.82	52.62	68.36	70.16
55 x 5	55.74	57.37	75.08	76.88
60 x 5	60.65	62.29	81.63	83.44

Standard Panel Sizes = 6100mm x 1000mm

All other types available upon request.

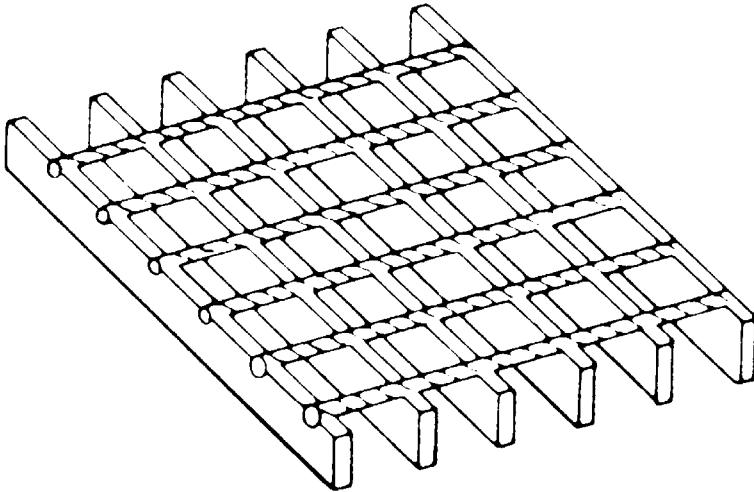

Flooring & Stairtreads

BS 4592-0:2006

BS 4592-1

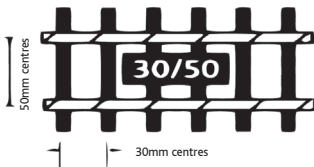
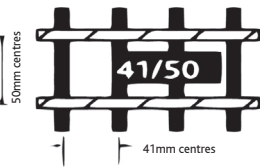
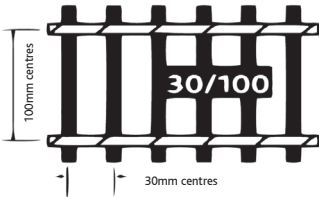
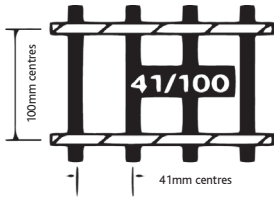

BS 4592-0 and -1 has been amended to come into line with the mandatory EN 14122, which states;

Category "A" All grating forming part of a platform or walkway should stop a 35mm diameter sphere.

Category "B" Grating where personnel are working below (rather than occasionally passing), should stop a 20mm diameter sphere.

Flooring & Stairtreads

Galvanised Fixing Clips

For health & safety reasons it is advisable to use a minimum of four butterfly or saddle clips per panel with extra clips as required.

FD 500 For type N (30mm between bars)

FD 501 For type W (41mm between bars)

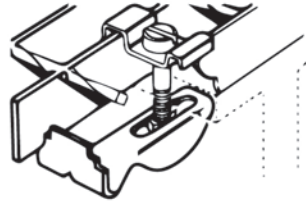

Stairtreads

We offer a comprehensive range of stairtreads.

- For Conventional or Spiral Stairways
- Trench Covers and Mezzanine Floors
- Vehicle Platforms, Ramps, etc.
- 3mm O/P to 12.5mm O/P

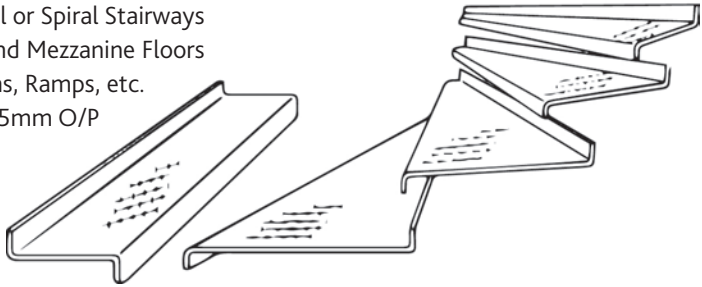

Diamond Pattern

Open Steel

Chequer Plate

Expanded

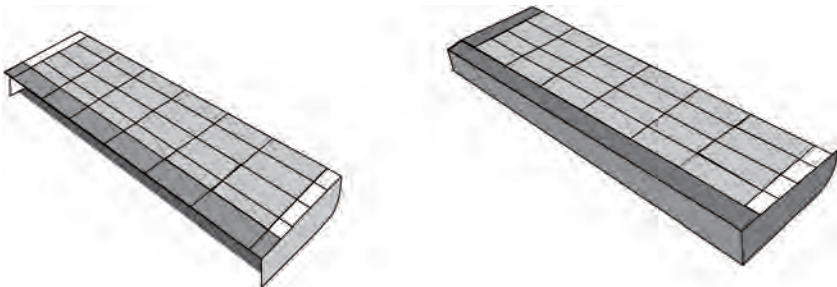

Flooring & Stairtreads

Universal Tread

- supplied in 41/100 25 x 5 x 1000mm long with only 1 end plate fitted the other loose (ideal for onsite fabrication work)

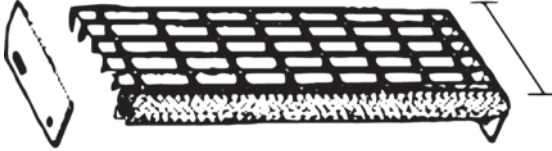

Available in three widths

242mm
275mm
283mm

Expanded Metal Walkway Meshes

- available in Mild Steel & Galvanised

Pattern Number	Lwd	Swd	Swdt	Stk	Kg/m ²	% Open Area	Stock Size
2496	60.96	24.80	6.10	4.50	17.29	51	2440 x 1220
4894	121.92	42.02	13.06	6.00	32.22	38	2265 x 1830
4896 #	121.92	36.80	6.35	4.50	13.23	65	2440 x 1220
4897 #	121.92	38.00	7.90	4.50	16.45	58	2440 x 1220
4899	121.92	38.06	9.53	6.00	24.98	50	1220 x 2440

Panels with mesh running either way.

Not for use with 2496
Use hook-bolts

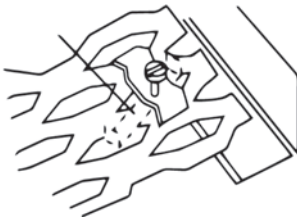

Expanded Metal

Expanded Raised Mesh

Pattern	Lwd	Swd	Swdt	Stk	Kg/m ²	% Open Area	Stock Size
220	5.84	3.50	0.79	0.60	2.11	55	1250 x 1250
203	10.24	5.64	0.79	0.60	1.31	72	1250 x 1250
209	10.24	5.64	1.55	1.00	4.30	45	1250 x 1250
199	14.29	5.64	1.17	1.00	3.25	59	1250 x 1250
798	19.05	7.43	1.70	1.00	3.59	54	2500 x 1250
1196	28.58	9.52	1.98	1.20	3.92	58	2440 x 1220
1292	30.48	12.70	4.75	2.50	14.67	25	1220 x 1525
1294	30.48	11.72	2.36	1.60	5.06	60	2440 x 1220
1295	30.48	11.72	1.98	1.60	4.24	66	2440 x 1220
1296	30.48	11.72	2.36	1.20	3.79	60	2440 x 1220
1298	30.48	11.72	1.63	1.00	2.17	72	2440 x 1220
1299	30.48	11.72	1.19	1.20	1.92	80	2440 x 1220
1576	38.10	16.93	4.75	3.00	13.20	44	2440 x 1220
1595	38.10	16.93	3.08	1.60	4.57	64	2440 x 1220
1597	38.10	16.48	2.25	1.60	3.43	73	2440 x 1220
1598	38.10	16.93	2.31	1.20	2.57	73	2440 x 1220
2088	50.80	22.58	3.89	3.00	8.09	66	2440 x 1220
2089	50.80	22.58	3.12	3.00	6.52	72	2440 x 1220
2091	50.80	22.58	2.52	2.50	4.37	78	2440 x 1220
2093	50.80	22.58	3.05	1.60	3.39	73	2440 x 1220
2096	50.80	22.58	2.34	1.20	1.95	79	2440 x 1220
3092	76.20	33.87	3.58	3.00	4.97	79	2440 x 1220
3095	76.20	33.87	3.89	3.00	5.39	77	2440 x 1220
3396	85.73	40.64	3.18	3.00	3.67	84	2440 x 1220
3398	85.73	39.33	2.59	2.50	2.59	87	2440 x 1220
4097	101.60	50.80	3.35	3.00	3.11	87	2440 x 1220
4599	114.30	39.33	4.58	3.00	5.48	77	2440 x 1220

Expanded Metal Continued

Expanded Flat Meshes

Pattern	Lwd	Swd	Swdt	Stk	Kg/m ²	% Open Area	Stock Size
226F	3.81	2.03	0.79	0.58	2.11	56	1250 x 1250
706F	2.79	0.81	0.76	0.58	3.01	35	1250 x 1250
217F	6.85	3.56	1.30	0.94	3.00	58	1250 x 2500
794F	14.22	4.83	1.85	0.96	3.30	57	1250 x 2500
1279F	23.11	5.84	3.20	1.52	6.27	48	2440 x 1220
1280F	24.38	7.11	2.39	1.14	3.64	60	2440 x 1220
1281F	24.38	7.87	2.06	1.47	4.07	66	2440 x 1220
1282F	24.38	7.62	2.08	1.14	3.17	65	2440 x 1220
1584F	32.77	10.92	3.18	1.50	4.41	63	2440 x 1220
1585F	33.53	12.45	2.34	1.14	2.47	73	2440 x 1220
2073F	42.93	14.22	4.60	2.69	8.59	61	2440 x 1220
2074F	39.12	18.29	4.72	2.74	7.55	66	1220 x 2440
2076F	43.43	18.03	2.31	1.14	1.85	80	2440 x 1220
2077F	43.18	17.27	3.23	1.45	3.24	73	2440 x 1220
2489F	46.99	15.49	6.63	4.20	14.81	54	1220 x 2440
3084F	68.83	28.70	2.83	1.45	1.88	84	2440 x 1220
3393F	77.47	27.18	6.53	2.82	7.15	68	2440 x 1220
3394F	69.84	37.08	5.49	2.16	3.97	77	1220 x 2440
3395F	76.96	32.77	3.81	1.85	2.80	81	2440 x 1220

Pre-galvanised Steel

N0921 F	25.15	8.64	1.65	0.94	2.06	72	2440 x 1070
---------	-------	------	------	------	------	----	-------------

Walkway Mesh

2496	60.96	24.80	6.10	4.50	17.29	51	2440 x 1220
4894	121.92	42.02	13.06	6.00	32.22	38	2265 x 1830
4896	121.92	36.80	6.35	4.50	13.23	65	2440 x 1220
4897	121.92	38.00	7.90	4.50	16.45	58	2440 x 1220
4899	121.92	38.06	9.53	6.00	24.98	50	1220 x 2440

Expanded Metal Continued

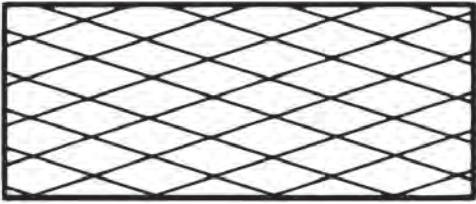

This sheet is 2440mm LWD and 1220mm SWD

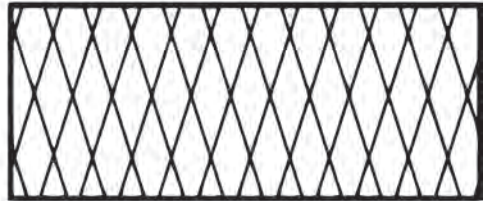

This sheet is 1220mm LWD and 2440mm SWD



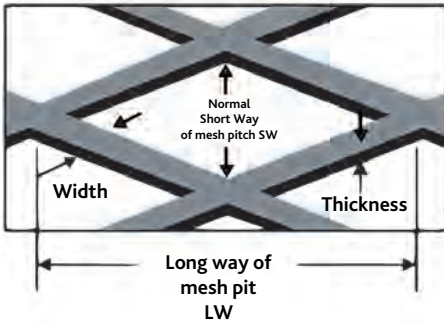



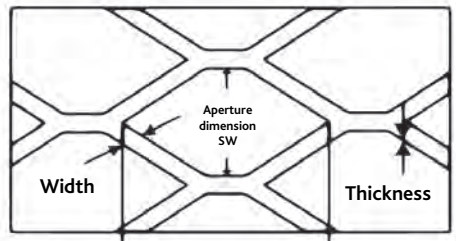











Conventional Mesh



Flattened Mesh

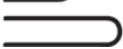

Edging Section

Ref.		Size mm	Thick mm	Gap mm	Weight Kg/m	Standard Length mm
UF1		6.35	1.20	1.78	0.13	2490
UF2		6.35	0.55	1.78	0.07	1905
UF3		12.70	0.90	1.78	0.18	2540
UF4		19.05	1.20	1.78	0.38	3810
UF5		31.48	1.20	1.78	0.62	3810
Suitable for framing Flattened Meshes up to and including 1.58mm.						
UF6		12.70	0.90	3.30	0.20	2540
UF7		19.05	1.20	3.30	0.38	3810
UF8		31.75	1.20	3.30	0.62	3810
Suitable for framing Flattened Meshes up to and including 3.18mm.						
UF6a		12.70	0.90	5.08	0.30	2540
UF9		19.05	1.20	5.08	0.38	3810
UF10		31.75	1.20	5.08	0.62	3810
Suitable for framing conventional mesh with a strand width of 2.39mm or under.						
UF11		19.05	1.50	10.16	0.45	3810
UF12		25.40	1.50	10.16	0.63	3810
UF13		25.40	2.95	10.16	1.20	3810
UF14		38.10	1.50	10.16	0.91	3810
UF15		38.10	2.95	10.16	1.79	3810
Suitable for framing conventional mesh with a strand width of 4.75mm or under.						
UF16		14.29	1.50	12.70	0.46	3810
Suitable for framing conventional mesh with a strand width of 6.09mm or under. Ideal for Walkway Mesh Patt 2496						
UF18		19.05	1.20	6.50	0.42	3810
UF19		31.75	1.20	6.50	0.66	3810
Suitable for framing up to 3.00mm Welded Mesh & Expanded with a strand width of up to 3.20mm						

Edging Section

LF1

Weight kg/m 0.88

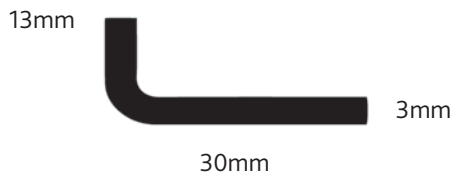

Suitable for framing expanded metal with a strand width of 4.75mm.
Standard length 2500mm.

LF2

Weight kg/m 0.34



Suitable for framing expanded metal with a strand width of 2.40mm or under and flattened expanded and welded mesh.
Standard length 2500mm.

Welded Mesh

Galvanised & Self Colour

Galvanised (After Manufacture)	8ft x 4ft 2440 x 1220 mm	12ft x 6ft 3660 x 1830 mm	6ft x 4ft 1830 x 1220 mm	6ft x 3ft 1830 x 915 mm
1" x 1" x 12g	●	●	●	●
3" x 1" x 12g	●	●	●	●
2" x 1" x 12g	●	●	●	●
2" x 2" x 12g	●	●	●	●
3" x 1/2" x 12g	●	●	●	●
1" x 1" x 10g	●	●	●	●
1 1/2" x 1 1/2" x 10g	●	●	●	●
2" x 1" x 10g	●	●	●	●
2" x 2" x 10g	●	●	●	●
3" x 1/2" x 10g	●	●	●	●
3" x 1" x 10g	●	●	●	●
3" x 3" x 10g	●	●	●	●
4" x 4" x 10g	●	●	●	●
1" x 1" x 8g	●	●	●	●
2" x 1" x 8g	●	●	●	●
2" x 2" x 8g	●	●	●	●
3" x 1/2" x 8g	●	●	●	●
3" x 3" x 8g	●	●	●	●
2" x 2" x 6g	●	●	●	●
3" x 3" x 6g	●	●	●	●
3" x 6" x 6g	●	●	●	●

Welded Mesh

12ft x 7ft 3660 x 2135 mm	60' Rolls with flush edges			Galvanised (After Manufacture)
	84" 2135mm	72" 1830mm	48" 1220mm	
●	●	●	●	1" x 1" x 12g
●	●	●	●	3" x 1" x 12g
●	●	●	●	2" x 1" x 12g
●	●	●	●	2" x 2" x 12g
●	●	●	●	3" x 1/2" x 12g
●	●	●	●	1" x 1" x 10g
●	●	●	●	1 1/2" x 1 1/2" x 10g
●	●	●	●	2" x 1" x 10g
●	●	●	●	2" x 2" x 10g
●	●	●	●	3" x 1/2" x 10g
●	●	●	●	3" x 1" x 10g
●	●	●	●	3" x 3" x 10g
●	●	●	●	4" x 4" x 10g
●	●	●	●	1" x 1" x 8g
●	●	●	●	2" x 1" x 8g
●	●	●	●	2" x 2" x 8g
●	●	●	●	3" x 1/2" x 8g
●	●	●	●	3" x 3" x 8g
●	●	●	●	2" x 2" x 6g
●	●	●	●	3" x 3" x 6g
●	●	●	●	3" x 6" x 6g

Plastic Coated Green on Galvanised Wire

Mesh Size mm	Specification Wire Dia. mm	Height	Weight per 25 metre rolls				
			0.9m kg	1.2m kg	1.5m kg	1.8m kg	2.4m kg
50 x 50	2.50/3.10		36.7	49.0	61.2	73.5	98
50 x 50	3.00/3.55		53.3	66.0	88.9	90.0	142.2

Line Wire for Fencing

Specification	Finish	Weight per Coil (kg)
2.50mm Dia.	Galvanised	25
3.00mm Dia.	Galvanised	25
4.00mm Dia.	Galvanised	25
3.55/2.50mm Dia.	Galv/PVC Green	25

Tying Wire for Fencing

Specification	Finish	Weight per Coil (kg)
1.60mm Dia. Wire	Galvanised	5
2.00/1.40mm Dia. Wire	Galv/PVC Green	5

Perforated Sheet

Mild Steel - Staggered Pitch

Hole Dia. mm(R)	Pitch mm(T)	Open Area %
1.0	2.0	23
1.2	2.25	25
1.5	2.75	26
2.0	3.0	40
2.0	3.5	30
2.0	4.0	23
2.5	3.5	46
3.0	4.0	50
3.0	5.0	32
4.0	5.0	58
4.0	6.0	40
4.0	7.0	29
5.0	6.0	63
5.0	7.0	45
5.0	8.0	35
5.0	10.0	23
6.0	8.5	45
6.0	10.0	32
6.0	12.0	23
8.0	11.0	47
8.0	12.0	40
10.0	13.0	53
10.0	15.0	40
10.0	18.0	28
12.0	13.0	77
12.0	17.0	45
15.0	21.0	46
20.0	27.0	51
20.0	30.0	39

Mild Steel - Square Pitch

Hole Dia. mm(R)	Pitch mm(T)	Open Area %
5.0	25.0	3
20.0	25.0	50

Pre-Galvanised Steel - Staggered Pitch

Hole Dia. mm(R)	Pitch mm(T)	Open Area %
2.0	3.5	30
3.0	5.0	32
4.0	8.0	23
5.0	7.0	45
5.0	8.0	35
8.0	11.0	47
10.0	13.0	53
10.0	15.0	40
20.0	27.0	51

Reinforcing Fabric

BS 4483 Fabric BRC Ref	Mesh Size Nominal Pitch of Wires		Diameter of Wire		Cross Section Area per metre width		Nominal Mass per m ² Kg
	Main mm	Cross mm	Main mm	Cross mm	Main mm	Cross mm	

Square Mesh

A393	200	200	10	10	393	393	6.16
A252	200	200	8	8	252	252	3.95
A193	200	200	7	7	193	193	3.02
A142	200	200	6	6	142	142	2.22
A98	200	200	5	5	98	98	1.54

Structural Mesh

B1131	100	200	12	8	1131	252	10.90
B785	100	200	10	8	785	252	8.14
B503	100	200	8	8	503	252	5.93
B385	100	200	7	7	385	193	4.53
B283	100	200	6	7	283	193	3.73
B196	100	200	5	7	196	193	3.05

Long Mesh

C785	100	400	10	6	785	70.8	6.72
C636	100	400	9	6	636	70.8	5.55
C503	100	400	8	5	503	49.0	4.34
C385	100	400	7	5	385	49.0	3.41
C283	100	400	6	5	283	49.0	2.61

Wrapping Mesh

D98	200	200	5	5	98.0	1.54	1.54
D49	100	100	2.5	2.5	49.0	0.77	0.77

Comparison Codes

Reinforcement Cut & Bent Bar

Preferred Shapes to BS 8666:2005
Reinforcement to BS 4449:2005 + A2:2009

Reinforcement Shaped Bar

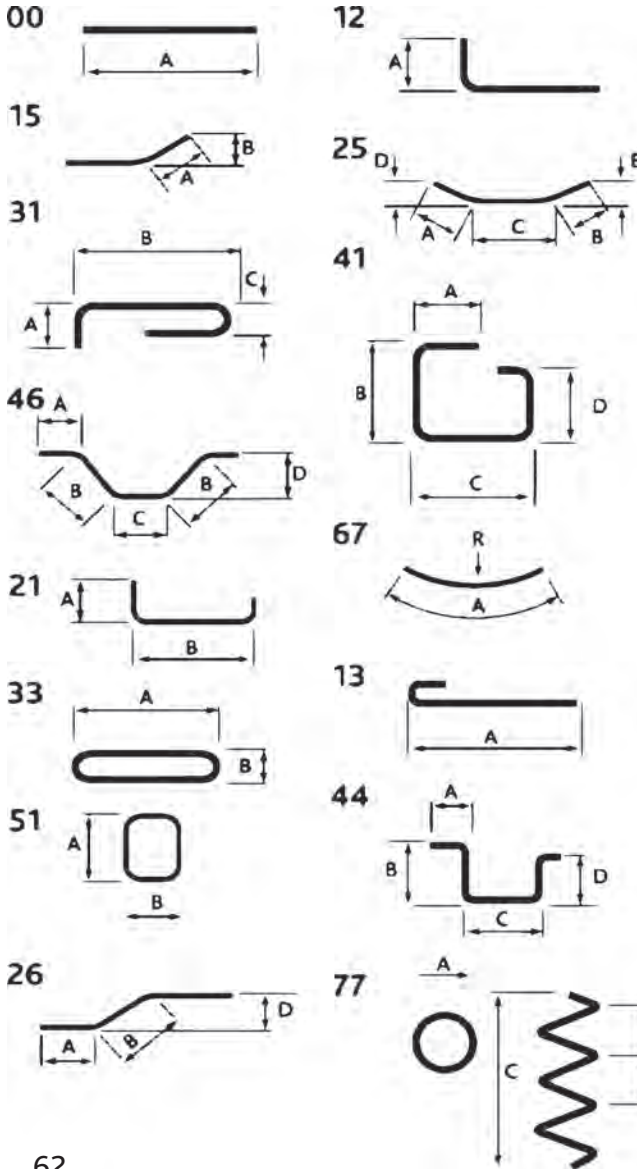

BS 4466 (1998)	BS 8666 (2000)
20	00
32	13
33	
34	11
35	
37	12
38	21
39	
41	26
42	
43	46
45	
49	25
51	
52	
53	44
54	
55	41
61	
62	15
65	67
77	
78	
79	
82	33
85	31
87	77

All other shapes are Shape Code 99 and require fully dimensioned sketches

Reinforcement Accessories

Pile Cages

- Specialists in helical and ring production for piling, underpinning and general engineering applications.

Tying Wire

- High quality 16 gauge tying wire as used by our own operations.
- Fully annealed, galvanised or stainless steel.
- Special loop end ties.
- Snips.
- Mould oil for shutters.
- Stainless steel dowels and rebar.

Concrete Spacers

- Cement type block spacers for reinforcing bar and mesh applications.
- Full bonding characteristics.
- Heavy duty applications.

Plastic Spacers

- Wheel type injection moulded for use in pile cage applications.
- Ensures continuous accurate cover and assists lowering of steel cage.

Mesh Spacers

- Fabric mesh support for light weight structures.
- Ideal on polythene membrane, geotextiles or sand beds.

Waffle Spacers

- Cement type block spacers for dowel bar support applications.
- Accurate and strong spacers for ends and floor joints.

Rebar Couplers

- All proprietary types.
- Full range of diameters available.
- Bar threading.
- Epoxy coating.

Hot Rolled Black Round

All material is produced in accordance with PD970:2005

Product Size mm	Kg/m	080A42	605M36T	708M40T	817M40T	655M13
30	5.55	●	●	●	●	●
35	7.55	●	●	●	●	●
40	9.86	●	●	●	●	●
42	10.86	●	●	●	●	●
45	12.50	●	●	●	●	●
50	15.40	●	●	●	●	●
55	18.70	●	●	●	●	●
60	22.20	●	●	●	●	●
65	26.00	●	●	●	●	●
70	30.20	●	●	●	●	●
75	34.70	●	●	●	●	●
80	38.50	●	●	●	●	●
85	44.50	●	●	●	●	●
90	49.90	●	●	●	●	●
95	55.60	●	●	●	●	●
100	61.60	●	●	●	●	●
105	68.00	●	●	●	●	●
110	74.60	●	●	●	●	●
115	81.55	●	●	●	●	●
120	88.00	●	●	●	●	●
130	104.00	●	●	●	●	●
140	121.00	●	●	●	●	●
145	130.00	●	●	●	●	●
150	139.00	●	●	●	●	●
160	158.00	●	●	●	●	●
170	178.00	●	●	●	●	●
180	200.00	●	●	●	●	●
185	211.00	●	●	●	●	●
190	222.37	●	●	●	●	●
200	247.00	●	●	●	●	●
210	272.00	●	●	●	●	●
220	298.00	●	●	●	●	●
230	326.00	●	●	●	●	●
240	356.00	●	●	●	●	●
250	385.00	●	●	●	●	●
260	416.30	●	●	●	●	●
270	448.00	●	●	●	●	●
280	482.00	●	●	●	●	●
290	518.00	●	●	●	●	●
310	592.00	●	●	●	●	●
330	670.80	●	●	●	●	●
345	733.90	●	●	●	●	●
350	754.60	●	●	●	●	●
380	889.50	●	●	●	●	●
390	937.00	●	●	●	●	●
440	1193.00	●	●	●	●	●
450	1247.00	●	●	●	●	●
500	1541.50	●	●	●	●	●

Hot Rolled Black Round

All material is produced in accordance with PD970:2005

Product Size mm	080A15	230M07	230M07 +PB	080M15	080A42	212A42	605M36T	708M40T	817M40T	655M13
3	●	●	●	●	●	●				
3.2	●	●	●	●	●	●				
4	●	●	●	●	●	●				
4.8	●	●	●	●	●	●				
5	●	●	●	●	●	●				
6	●	●	●	●	●	●				
6.35	●	●	●	●	●	●				
6.4	●	●	●	●	●	●				
7.9	●	●	●	●	●	●				
8	●	●	●	●	●	●				
9	●	●	●	●	●	●				
9.5	●	●	●	●	●	●				
10	●	●	●	●	●	●	●	●	●	●
11.1	●	●	●	●	●	●	●	●	●	●
12	●	●	●	●	●	●	●	●	●	●
12.7	●	●	●	●	●	●	●	●	●	●
14.3	●	●	●	●	●	●	●	●	●	●
15	●	●	●	●	●	●	●	●	●	●
15.88	●	●	●	●	●	●	●	●	●	●
16	●	●	●	●	●	●	●	●	●	●
17	●	●	●	●	●	●	●	●	●	●
18	●	●	●	●	●	●	●	●	●	●
19	●	●	●	●	●	●	●	●	●	●
19.05	●	●	●	●	●	●	●	●	●	●
20	●	●	●	●	●	●	●	●	●	●
22	●	●	●	●	●	●	●	●	●	●
22.2	●	●	●	●	●	●	●	●	●	●
24	●	●	●	●	●	●	●	●	●	●
25	●	●	●	●	●	●	●	●	●	●
25.4	●	●	●	●	●	●	●	●	●	●

Cold Drawn Bright Round

All material is produced in accordance with PD970:2005

Product Size mm	080A15	230M07	230M07+Pb	080A42	212A42	605M36T	708M40T	807M40T	655M13
26	●	●	●	●	●	●	●	●	●
27	●	●	●	●	●	●	●	●	●
28	●	●	●	●	●	●	●	●	●
28.6	●	●	●	●	●	●	●	●	●
30	●	●	●	●	●	●	●	●	●
31.75	●	●	●	●	●	●	●	●	●
32	●	●	●	●	●	●	●	●	●
34.9	●	●	●	●	●	●	●	●	●
35	●	●	●	●	●	●	●	●	●
36	●	●	●	●	●	●	●	●	●
38.1	●	●	●	●	●	●	●	●	●
40	●	●	●	●	●	●	●	●	●
41.3	●	●	●	●	●	●	●	●	●
42	●	●	●	●	●	●	●	●	●
44.5	●	●	●	●	●	●	●	●	●
45	●	●	●	●	●	●	●	●	●
47.6	●	●	●	●	●	●	●	●	●
48.3	●	●	●	●	●	●	●	●	●
50	●	●	●	●	●	●	●	●	●
50.8	●	●	●	●	●	●	●	●	●
52	●	●	●	●	●	●	●	●	●
55	●	●	●	●	●	●	●	●	●
57.1	●	●	●	●	●	●	●	●	●
60	●	●	●	●	●	●	●	●	●
60.3	●	●	●	●	●	●	●	●	●
63.5	●	●	●	●	●	●	●	●	●
65	●	●	●	●	●	●	●	●	●
69.8	●	●	●	●	●	●	●	●	●
70	●	●	●	●	●	●	●	●	●
75	●	●	●	●	●	●	●	●	●
76.1	●	●	●	●	●	●	●	●	●
80	●	●	●	●	●	●	●	●	●
82.5	●	●	●	●	●	●	●	●	●
85	●	●	●	●	●	●	●	●	●
88.9	●	●	●	●	●	●	●	●	●
90	●	●	●	●	●	●	●	●	●
95	●	●	●	●	●	●	●	●	●
100	●	●	●	●	●	●	●	●	●
101.6	●	●	●	●	●	●	●	●	●
108	●	●	●	●	●	●	●	●	●
114.3	●	●	●	●	●	●	●	●	●
115	●	●	●	●	●	●	●	●	●
120	●	●	●	●	●	●	●	●	●
125	●	●	●	●	●	●	●	●	●
127	●	●	●	●	●	●	●	●	●
130	●	●	●	●	●	●	●	●	●
140	●	●	●	●	●	●	●	●	●
150	●	●	●	●	●	●	●	●	●
152.4	●	●	●	●	●	●	●	●	●
177.8	●	●	●	●	●	●	●	●	●

Cold Drawn Bright Flats

All material is produced in accordance with PD970:2005

Product Size	080A15	Product Size	080A15	Product Size	080A15
9.5 x 6.3	●	20 x 6	●	35 x 6	●
10 x 3	●	20 x 10	●	35 x 12	●
10 x 5	●	20 x 12	●	35 x 15	●
10 x 6	●	20 x 16	●		
		22 x 3	●	38.1 x 3.2	●
12 x 3	●			38.1 x 4.8	●
12 x 5	●	25 x 3	●	38.1 x 6.3	●
		25 x 5	●	38.1 x 9.5	●
12.7 x 3.2	●	25 x 6	●	38.1 x 12.7	●
12.7 x 4.8	●	25 x 8	●		
12.7 x 6.3	●	25 x 10	●	40 x 3	●
12.7 x 7.9	●	25 x 12	●	40 x 5	●
12.7 x 9.5	●	25 x 16	●	40 x 6	●
		25 x 20	●	40 x 8	●
15 x 3	●			40 x 10	●
15 x 4	●	25.4 x 3.2	●	40 x 12	●
15 x 5	●	25.4 x 4.8	●	40 x 16	●
15 x 6	●	25.4 x 6.3	●	40 x 20	●
15 x 8	●	25.4 x 9.5	●	40 x 25	●
15 x 10	●	25.4 x 12.7	●	40 x 30	●
		25.4 x 15.9	●		
15.9 x 3.2	●	25.4 x 19.1	●	44.45 x 12.7	●
15.9 x 4.8	●				
15.9 x 6.3	●	30 x 3	●	45 x 25	●
15.9 x 6.35	●	30 x 5	●		
15.9 x 9.5	●	30 x 6	●	50 x 5	●
15.9 x 12.7	●	30 x 8	●	50 x 6	●
		30 x 10	●	50 x 8	●
16 x 3	●	30 x 12	●	50 x 10	●
16 x 5	●	30 x 16	●	50 x 12	●
16 x 6	●	30 x 20	●	50 x 16	●
16 x 10	●	30 x 25	●	50 x 20	●
16 x 12	●			50 x 25	●
		31.75 x 3.2	●	50 x 30	●
19.1 x 3.2	●	31.75 x 6.35	●	50 x 40	●
19.1 x 4.8	●	31.75 x 9.5	●		
19.1 x 7.9	●	31.75 x 19.05	●	50.8 x 3.2	●
19.1 x 9.5	●			50.8 x 6.3	●
19.1 x 12.7	●			50.8 x 9.5	●
19.1 x 15.9	●	31.8 x 12.7	●	50.8 x 12.7	●
		31.8 x 15.9	●	50.8 x 15.9	●
20 x 3	●	31.8 x 25.4	●	50.8 x 19.1	●
20 x 4	●			50.8 x 25.4	●
20 x 5	●	32 x 16	●	50.8 x 31.8	●
				50.8 x 38.1	●

Cold Drawn Bright Flats

All material is rolled in accordance with PD970:2005

Product Size	080A15	Product Size	080A15	Product Size	080A15
60 x 6	●	76.2 x 12.7	●	125 x 10	●
60 x 8	●	76.2 x 19.1	●	125 x 12	●
60 x 10	●	76.2 x 25.4	●	125 x 20	●
60 x 12	●	76.2 x 50.8	●	125 x 25	●
60 x 16	●				
60 x 20	●	80 x 6	●	127 x 12.7	●
60 x 25	●	80 x 8	●	127 x 25.4	●
60 x 30	●	80 x 10	●		
60 x 40	●	80 x 12	●	150 x 10	●
		80 x 16	●	150 x 12	●
63.5 x 3.2	●	80 x 20	●	150 x 25	●
63.5 x 6.3	●	80 x 25	●	150 x 30	●
63.5 x 6.5	●	80 x 40	●		
63.5 x 15.8	●			152.4 x 6.3	●
63.5 x 19.05	●	88.9 x 9.5	●	152.4 x 9.5	●
63.5 x 25.4	●	88.9 x 12.7	●	152.4 x 12.7	●
63.5 x 44.4	●			152.4 x 15.9	●
63.5 x 50.8	●	90 x 16	●	152.4 x 19.05	●
		90 x 25	●	152.4 x 19.1	●
65 x 10	●	90 x 50	●	152.4 x 25.4	●
65 x 12	●			152.4 x 50.8	●
65 x 16	●	100 x 6	●		
65 x 20	●	100 x 8	●	178 x 25.4	●
65 x 30	●	100 x 10	●		
		100 x 12	●	200 x 6	●
70 x 12	●	100 x 16	●	200 x 12	●
70 x 16	●	100 x 20	●	200 x 25	●
70 x 20	●	100 x 25	●		
70 x 40	●	100 x 30	●	203 x 12.7	●
		100 x 50	●	203.2 x 25.4	●
75 x 6	●			203.2 x 50.8	●
75 x 8	●	101.6 x 3.2	●	203 x 31.8	●
75 x 10	●	101.6 x 6.3	●		
75 x 12	●	101.6 x 9.5	●	254 x 15.9	●
75 x 20	●	101.6 x 12.7	●		
75 x 25	●	101.6 x 19.1	●	304.8 x 12.7	●
75 x 50	●	101.6 x 25.4	●	304.8 x 15.9	●
		101.6 x 50.8	●		
76.1 x 9.52	●	101.6 x 76.2	●		
76.1 x 19.1	●				
76.1 x 25.4	●	101.8 x 19.1	●		
		101.8 x 25.4	●		
76.2 x 6.3	●	101.8 x 50.8	●		
76.2 x 9.5	●	101.8 x 76.1	●		
76.2 x 3.2	●				

Cold Rolled Bright Squares

Product Size mm	080A15	080A42
5	●	
6	●	
6.3	●	
6.35	●	
8	●	
9.5	●	
10	●	
11.1		●
12	●	
12.7	●	●
14	●	
15	●	
15.8	●	
15.9	●	
16	●	
18	●	
19		
19.1	●	●
20	●	
22	●	
22.2	●	
25	●	
25.4	●	
30	●	●
31.7	●	
31.8	●	
32	●	
35	●	
38.1	●	
40	●	
44.45	●	
45	●	
50	●	●
50.8	●	●
60	●	
70		
75	●	
76.1	●	
76.2		
80	●	
101.6	●	
127	●	
130		
152	●	

Cold Rolled Bright Hexagon

Product Size mm	080A15	230M07	230M07 +PB
7.9	●	●	●
8	●	●	●
10	●	●	●
11	●	●	●
13	●	●	●
14	●	●	●
19	●	●	●
19.1	●	●	●
22	●	●	●
24	●	●	●
25	●	●	●
25.4	●	●	●
30	●	●	●
32	●	●	●
33.02	●	●	●
35	●	●	●
36	●	●	●
38.1	●	●	●
65	●	●	●
80	●	●	●

Bright Angles & Key Steel

Key		Angle	
Product Size		Product Size	
8 x 7		16 x 16 x 3	
10 x 8		20 x 20 x 3	
12 x 8		25 x 25 x 3	
14 x 9		25 x 25 x 5	
15.9 x 11.1		32 x 32 x 4	
15.9 x 12.7		32 x 32 x 6	
18 x 11		40 x 40 x 6	
19.1 x 12.7		40 x 40 x 6	
20 x 12			
22.2 x 15.9			
22 x 14			
25.4 x 12.7			
25.4 x 15.9			
25.4 x 19.1			
25 x 14			
28 x 16			
31.8 x 19.1			
31.8 x 22.2			
32 x 18			
36 x 20			
40 x 22			
50.8 x 31.8			
50 x 28			

● **Please note:** All material is produced in accordance with PD970:2005

Technical Information

Conversion Factors

To Convert	Multiply by
Centimetres to inches	0.3937
Cubic centimetres to cubic inches	0.06103
Cubic feet to cubic metres	0.02832
Cubic inches to cubic centimetres	16.39
Cubic inches to litres	0.01639
Cubic metres to cubic feet	35.32
Cubic metres to cubic yards	1.308
Cubic yards to cubic metres	0.7645
Feet to metres	0.3048
Foot pounds to kilogram metres	0.1382
Gallons to litres	4.536
Gallons to cubic feet	0.1606
Grains to grams	0.06480
Grams to pounds	0.002205
Inches to centimetres	2.540
Inches to millimetres	25.40
Kilogram metres to foot pounds	7.233
Kilograms to pounds	2.205
Kilograms to tons	0.0009842
Kilos per sq. mm to tons per sq. inch	0.635
Metres to feet	3.281
Millimetres to inches	0.0394
N/mm ² to tons f/in ²	0.06475
Pounds to kilograms	0.4536
Pounds per foot to kilos per metre	1.488
Square centimetres to sq. inches	0/1550
Square feet to sq. metres	0.09290
Square inches to sq. centimetres	6.452
Square metres to sq. feet	10.76
Temperature conversion:-	°C = 5/9 (°F - 32)
	°F = (9/5 °C) + 32
Tons per sq. inch to kilos per sq. mm	1.575
Tons f/in. ² to N/mm ²	15.444
Tons to kilograms	1016.0
KSI - Nmm ² ÷ 0.145038	
Nmm ² - KSI x 0.145038	

Technical Information

Symbols used in EN 10025 : part 2 : 2004

Non-alloy structural steels

- S...** Structural steel
- E...** Engineering steel
- .235...** Minimum yield strength (ReH) in MPa @ 16mm
- ...JR..** Longitudinal Charpy V-notch impacts 27 J @ +20°C
- ...J0..** Longitudinal Charpy V-notch impacts 27 J @ 0°C
- ...J2..** Longitudinal Charpy V-notch impacts 27 J @ -20°C
- ...K2..** Longitudinal Charpy V-notch impacts 40 J @ -20°C
- ...+AR** Supply condition as rolled
- ...+N** Supply condition normalised or normalised rolled

Customer options

- ...C..** Grade Suitable for cold forming
- ...Z..** Grade with improved properties perpendicular to the surface

Examples: **S235JR+AR**, **S355K2C+N**

Symbols used in EN 10025 : part 3 : 2004

Normalised /normalised rolled weldable fine grain structural steels

- S...** Structural steel
- .275...** Minimum yield strength (ReH) in MPa @ 16mm
- ...N..** Longitudinal Charpy V-notch impacts at a temperature not lower than -20°C
- ...NL..** Longitudinal Charpy V-notch impacts at a temperature not lower than -50°C

Customer options

- ...Z..** Grade with improved properties perpendicular to the surface

Examples: **S275N**, **S420NL Z35**

Technical Information

Grade Designation Systems

Symbols used in EN 10025 : part 4 : 2004 Thermomechanical rolled weldable fine grain structural steels

- S...** Structural steel
- .275...** Minimum yield strength (ReH) in MPa @ 16mm
- ...M..** Longitudinal Charpy V-notch impacts at a temperature not lower than -20°C
- ...ML..** Longitudinal Charpy V-notch impacts at a temperature not lower than -50°C

Customer options

- ...Z..** Grade with improved properties perpendicular to the surface

Examples: **S355M**, **S460ML Z25**

Symbols used in EN 10025 : part 5 : 2004 Structural Steels with improved atmospheric corrosion resistance - also known as weathering steels

- S...** Structural steel
- .355...** Minimum yield strength (ReH) in MPa @ 16mm
- ...J0..** Longitudinal Charpy V-notch impacts 27 J @ 0°C
- ...J2..** Longitudinal Charpy V-notch impacts 27 J @ -20°C
- ...K2..** Longitudinal Charpy V-notch impacts 40 J @ -20°C
- ...W..** Improved atmospheric corrosion resistance
- ...P..** Greater phosphorous content (grade S355 only)
- ...+AR** Supply condition as rolled
- ...+N** Supply condition normalised or normalised rolled

Customer options

- ...Z..** Grade with improved properties perpendicular to the surface

Examples: **S235JOW+AR**, **S355K2W+N Z25**

Technical Information

Grades, properties and nearest equivalents

The tables below show the grades, properties and nearest equivalent grades from earlier standards. The grade designations are explained on the previous pages.

Table 1

EN 10025 : part 2 : 2004 Non-alloy structural steels						
Comparison between grades in EN 10025 : part 2 : 2004 and nearest equivalent versions in EN 10025 : 1993 and BS 4360 : 1990						
Grade	EN 10025 : part 2 : 2004		EN 10025 : 1993		BS 4360 : 1990	
	Yield (Reh) min Strength at t = 16mm (MPa)	Tensile (Rm)	Charpy V-notch longitudinal Temp (°C)	Energy (J) t = 16mm	Grade	Grade
S185	185	290/510	-	-	S185	-
-¹	235	360/510	-	-	S235	40A
S235JR²			20	27	S235JR	40B
S235J0			0	27	S235J0	40C
S235J2			-20	27	S235J2G3/G4	40D
-¹	275	410/560	-	-	S275	43A
S275JR²			20	27	S275JR	43B
S275J0			0	27	S275J0	43C
S275J2			-20	27	S275J2G3/G4	43D
-¹	355	470/360	-	-	S355	50A
S355JR²			20	27	S355JR	50B
S355J0			0	27	S355J0	50C
S355J2			-20	27	S355J2G3/G4	50D
S355K2			-20	40	S355K2G3/G4	50DD
E295	295	470/610	-	-	E295	-
S335	335	570/710	-	-	S335	-
E360	360	650/830	-	-	E360	-

1 MPa=1 N/mm²

Notes

- For all products to be compliant with the EU Construction Products Directive (CPD 89/106/EC) the material must offer a guaranteed minimum impact performance. This resulted in the removal of this grade from the standard, and the lowest grade now offered is the JR version for each yield strength variation.
- Verification of the specified impact value is only carried out when agreed at the time of the enquiry and order.

Technical Information

Grades, properties and nearest equivalents

Table 2

EN 10025 : part 3 : 2004 Normalised / normalised rolled weldable fine grain structural steels						
Comparison between grades in EN 10025 : part 3 : 2004 and nearest equivalent versions in EN 10113 : part 2 : 1993 and BS 4360 : 1990						
EN 10025 : part 3 : 2004					EN 10113 : part 2 : 1993	BS 4360 : 1990
Grade	Yield (Reh) min	Tensile (Rm)	Charpy V-notch longitudinal		Grade	Grade
	Strength at t = 16mm (MPa)		Temp (°C)	Energy (J) t = 16mm		
S275N	275	370/510	-20	40	S275N	43DD
S275NL			-50	27	S275NL	43EE
S355N	355	470/630	-20	40	S355N	50
S355NL			-50	27	S355NL	50EE
S420N	420	520/680	-20	40	S420N	-
S420NL			-50	27	S420NL	-
S460N	460	550/720	-20	40	S460N	55C
S460NL			-50	27	S460NL	55EE

1 MPa=1 N/mm²

Table 3

EN 10025 : part 4 : 2004 Thermomechanically rolled weldable fine grain structural steels						
Comparison between grades in EN 10025 : part 4 : 2004 and nearest equivalent versions in EN 10113 : part 3 : 1993						
EN 10025 : part 4 : 2004					EN 10113 : part 3 : 1993	
Grade	Yield (Reh) min	Tensile (Rm)	Charpy V-notch longitudinal		Grade	Grade
	Strength at t = 16mm (MPa)		Temp (°C)	Energy (J) t = 16mm		
S275M	275	370/510	-20	40	S275M	
S275ML			-50	27	S275ML	
S355M	355	470/630	-20	40	S355M	
S355ML			-50	27	S355ML	
S420M	420	520/680	-20	40	S420M	
S420ML			-50	27	S420ML	
S460M	460	550/720	-20	40	S460M	
S460ML			-50	27	S460ML	

1 MPa=1 N/mm²

Technical Information

Grades, properties and nearest equivalents

Table 4

EN 10025 : part 5 : 2004 Structural steels with improved atmospheric corrosion resistance - also known as weathering steels						
Comparison between grades in EN 10025 : part 5 : 2004 and nearest equivalent versions in EN 10155 : 1993 and BS 4360 : 1990						
EN 10025 : part 5 : 2004				EN 10115 : 1993	BS 4360 : 1990	
Grade	Yield (Reh) min	Tensile (Rm)	Charpy V-notch longitudinal		Grade	Grade
	Strength at t = 16mm (MPa)		Temp (°C)	Energy (J) t = 16mm		
S235J0W	235	360/510	0	27	S235J0W	-
S235J2W			-20	27	S235J2W	-
S355J0WP	355	470/630	0	27	S355J0WP	WR50A
S355J2WP			-20	27	S355J2WP	-
S355J0W	355	470/630	0	27	S355J0W	WR50B
S355J2W			-20	27	S355J2W	WR50C
S355K2W			-20	40	S355K2W	WR50D

1 MPa=1 N/mm²

Technical Information

Symbols used in EN 10025 : part 6 : 2004

Flat products of high yield strength structural steels in the quenched and tempered condition

- S...** Structural steel
- .460...** Minimum yield strength (Reh) in MPa @ 16mm
- ...Q..** Longitudinal Charpy V-notch impacts at a temperature not lower than -20°C
- ...QL..** Longitudinal Charpy V-notch impacts at a temperature not lower than -40°C
- ...QL1..** Longitudinal Charpy V-notch impacts at a temperature not lower than -60°C

Customer options

- ...Z..** Grade with improved properties perpendicular to the surface

Examples: S460Q, S690QL

Technical Information

Grades, properties and nearest equivalents

Table 5

EN 10025 : part 6 : Flat products of high yield strength structural steels in the quenched and tempered condition						
Comparison between grades in EN 10025 : part 6 : 2004 and nearest equivalent versions in EN 10137 : part 2 : 1996 and BS 4360 : 1990						
EN 10025 : part 6 : 2004				EN 10137 : part 2 : 1996	BS 4360 : 1990	
Grade	Yield (Reh) min	Tensile (Rm)	Charpy V-notch longitudinal		Grade	Grade
	Strength at t =	16mm (MPa)	Temp (°C) ¹	Energy (J) t = 16mm		
S460Q	460	550/720	0	40	S460Q	-
S460QL			0	50	S460QL	-
S460QL1			0	60	S460QL1	55F
S500Q	500	590/770	0	40	S500Q	-
S500QL			0	50	S500QL	-
S500QL1			0	60	S500QL1	-
S550Q	550	640/820	0	40	S550Q	-
S550QL			0	50	S550QL	-
S550QL1			0	60	S550QL1	-
S620Q	620	700/890	0	40	S620Q	-
S620QL			0	50	S620QL	-
S620QL1			0	60	S620QL1	-
S690Q	690	770/940	0	40	S690Q	-
S690QL			0	50	S690QL	-
S690QL1			0	60	S690QL1	-
S890Q	890	940/1100	0	40	S890Q	-
S890QL			0	50	S890QL	-
S890QL1			0	60	S890QL1	-
S960Q	960	980/1150	0	40	S960Q	-
S960QL			0	50	S960QL	-

Note

Other impact temperatures can be specified.

1 MPa=1 N/mm²

Value Added Services



TUBE LASER

- Cutting Beams, Columns, Hollow Sections, Split Tees, Angles and Channels
- 2D & 3D cutting
- Accuracy and Repeatability guaranteed



FLAT BED LASER

- Cutting: max length 4000mm
- Max width 2000mm
- Fiber laser cutting and CO₂ technology
- Max sheet thickness - Steel 20mm, Stainless 25mm and Aluminium 15mm



PROFILING

- HD Plasma cutting up to 100mm thick
- Oxy-Fuel up to 200mm thick
- Drilling
- Beveling



PRESS BRAKE

- Bystronic Xpert
- 320T / 4100
- Max length 4100mm



SAWING

- Carbon Steel Long Products & Hollow Sections
- Length capacity > 22.0m
- Square & Mitre cutting > 60°



DRILLING

- Carbon Steel Universal & Plate Beams / Channels & Angles
- Hole diameter 8mm > 40mm / length capacity > 21.0m



FABRICATION

- Cutting Asymmetric & Cambered beams up to 20m
- Drilling up to 40mm, diameter up to 100mm thick
- Milling up to 250mm
- Saw & drill up to 20m length, 500mm width and 1155mm depth



SHOT BLASTING & PAINTING

- Modern fully automated shot blasting and painting lines can handle plates and structural material up to 22m long, 1500mm wide and 500mm high, the maximum weight capacity is 10 tonnes
- We offer a blast finish to SA2.5 in paint colours of red and grey



DE-COILING

- Carbon Steel (Cold Rolled) / Coated (Galvanised Pre-Paint / Specialist)
- Gauge range 0.4mm > 3.0mm
- Slitting / Re-coiling / Shearing related services available



ASD | Head Office

Valley Farm Road, Stourton, Leeds,
West Yorkshire, LS10 1SD

t: 0113 254 0711

e: enquiries@kloeckner.com

www.asd.ltd